



## Review article

## Overview of wall probes for erosion and deposition studies in the TEXTOR tokamak

M. Rubel <sup>a,\*</sup>, S. Brezinsek <sup>b</sup>, J.W. Coenen <sup>b</sup>, A. Huber <sup>b</sup>, A. Kirschner <sup>b</sup>, A. Kreter <sup>b</sup>, P. Petersson <sup>a</sup>, V. Philipps <sup>b</sup>, A. Pospieszczyk <sup>b</sup>, B. Schweer <sup>b</sup>, G. Sergienko <sup>b</sup>, T. Tanabe <sup>c</sup>, Y. Ueda <sup>d</sup>, P. Wienhold <sup>b</sup><sup>a</sup> Department of Fusion Plasma Physics, Royal Institute of Technology, S-100 44 Stockholm, Sweden<sup>b</sup> Forschungszentrum Jülich GmbH, Institut für Energie- und Klimaforschung – Plasmaphysik, Partner of the Trilateral Euregio Cluster (TEC), 52425 Jülich, Germany<sup>c</sup> Interdisciplinary Graduate School of Engineering Science, Kyushu University, Japan<sup>d</sup> Graduate School of Engineering, Osaka University, Osaka 565-0871, Japan

Received 26 November 2016; revised 23 February 2017; accepted 27 March 2017

Available online 3 May 2017

**Abstract**

An overview of diagnostic tools – test limiters and collector probes – used over the years for material migration studies in the TEXTOR tokamak is presented. Probe transfer systems are shown and their technical capabilities are described. This is accompanied by a brief presentation of selected results and conclusions from the research on material erosion – deposition processes including tests of candidate materials (e.g. W, Mo, carbon-based composites) for plasma-facing components in controlled fusion devices. The use of tracer techniques and methods for analysis of materials retrieved from the tokamak are summarized. The impact of research on the reactor wall technology is addressed.

© 2017 Science and Technology Information Center, China Academy of Engineering Physics. Publishing services by Elsevier B.V. This is an open access article under the CC BY-NC-ND license (<http://creativecommons.org/licenses/by-nc-nd/4.0/>).

PACS codes: 52.40.Hf; 52.25.Vy; 82.80.Yc; 68.55.Ln

Keywords: Erosion–deposition; Material migration; Deuterium retention; Carbon; Tungsten; TEXTOR

**1. Introduction**

TEXTOR was a medium size tokamak operated in years 1982–2013 at the Institute of Plasma Physics of Forschungszentrum Jülich, Germany [1]. The name TEXTOR stands for **T**orus **EX**periment for **T**echnology **O**riented **R**esearch. This indicates the major mission of the tokamak: significant contribution to fusion technology and science with particular emphasis on plasma – wall interactions (PWI), which comprise all processes involved in the exchange of mass and energy between plasma and the surrounding wall [2]. PWI is a vast interdisciplinary field where plasma physics meets

solid state physics including materials science, material analysis, surface physics and chemistry. Two inter-related aspects of future reactor operation – economy and safety – are the driving forces for studies of PWI. It is also one of the primary areas where the integration of physics and technology programs is being achieved. Strategic goals in studies of PWI phenomena are to build practical experience and a robust data base for the next-step device, i.e. ITER. Interests and efforts are focused on the assessment of: (i) material lifetime by various erosion–deposition processes; (ii) retention of hydrogen isotopes in order to contribute to predictions of tritium inventory; (iii) dust generation.

Research carried out at TEXTOR covered the development and testing of plasma-facing materials (PFM) and components (PFC) (e.g. [3–7]), development of wall conditioning techniques [8–10], plasma heating scenarios, plasma edge control

\* Corresponding author.

E-mail address: [marek.rubel@ee.kth.se](mailto:marek.rubel@ee.kth.se) (M. Rubel).

Peer review under responsibility of Science and Technology Information Center, China Academy of Engineering Physics.

[11] and disruption mitigation [12], validation of codes to deepen understanding of material transport [13], design and application of a great number of plasma diagnostics including those for PWI studies [1]. Since early days a broad international cooperation has been built around International Energy Agency (IEA) – TEXTOR Implementing Agreement, involving tens of teams from Europe, Canada, Japan, Russia and the USA. More than a thousand original works have been published and several hundreds of doctoral students gained experience and then greatly contributed to the development of fusion science. In year 2005 a comprehensive summary of research at TEXTOR has been presented in a special volume of Fusion Science and Technology [1].

The aim of the present paper is to provide an overview of erosion–deposition probes including presentation of methods

used for their study and to briefly address the major outcome of research. We first introduce main in-vessel components and also transfer systems for material probes used for PWI studies. The presentation of various test limiters and probe heads is accompanied by the description of their application in various research programs. This is followed by the information on analysis methods used in the examination of probes.

## 2. TEXTOR tokamak

### 2.1. Wall components

TEXTOR was a limiter machine of a circular cross-section. A collection of images in Fig. 1 shows toroidal views into the vacuum vessel. It is an illustrated history of the plasma-facing

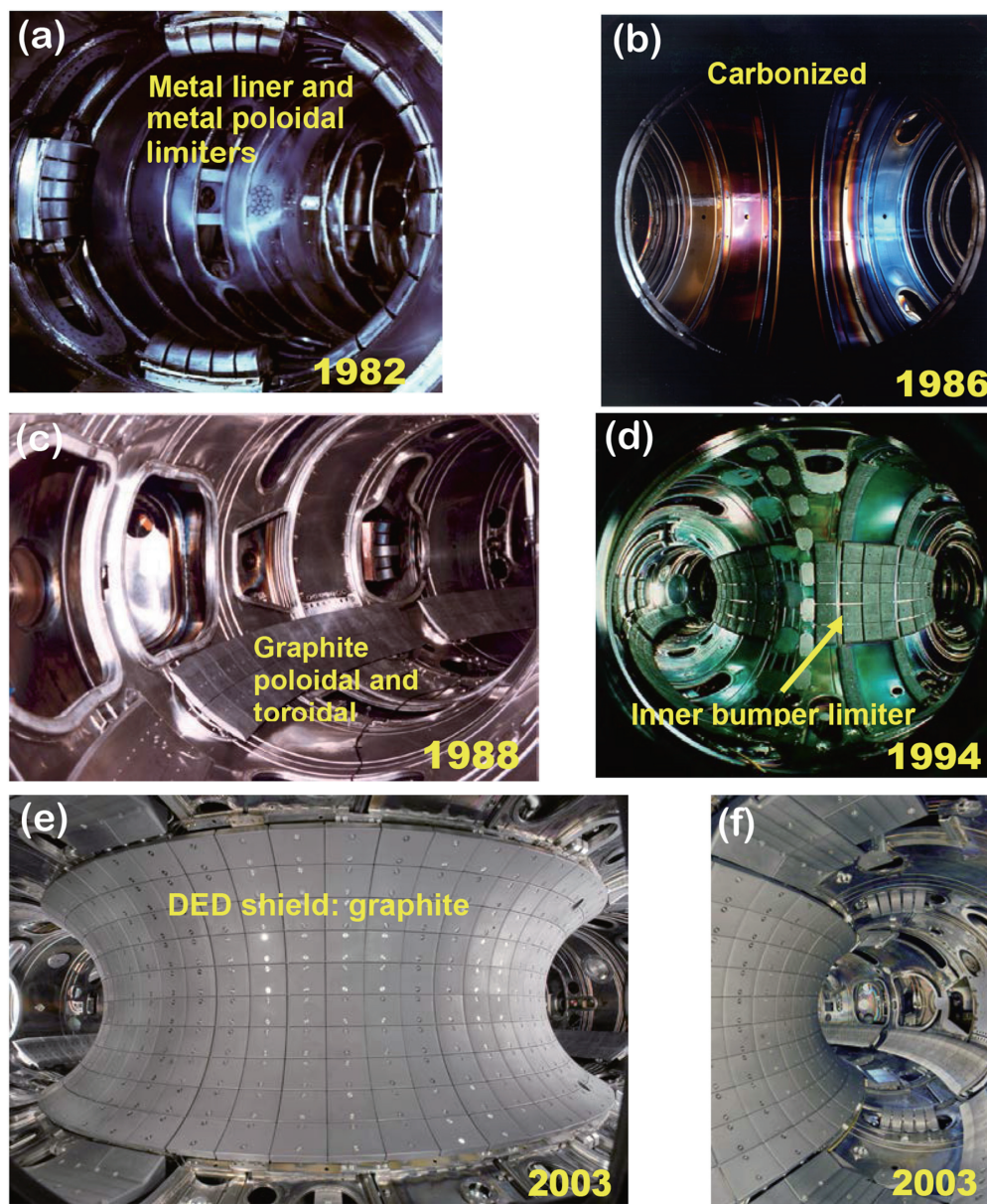

Fig. 1. TEXTOR vacuum vessel over the years: general view of plasma-facing components (photo: H. Reimer).



wall, a history of changes and development of PFC. It should be stressed that there was a number of particular, even unique, features in wall construction. One of them was a liner made of Inconel alloy, i.e. “vessel-in-vessel” which could be heated up to 620 K. TEXTOR started operation as a machine with metal wall components: liner and three arrays of poloidal limiters made of stainless steel, as shown in Fig. 1(a). Erosion of medium-Z and high-Z metal components (eroded limiter blocks are in Fig. 2) and its impact on impurity release to plasma led to the implementation of low-Z materials on the wall: modification of wall composition and installation of new PFC. Wall modification by conditioning techniques started in year 1985 with carbonisation [8] which was followed by boronisation [9] and siliconisation [10] all increasing substantially the operational window and pulse duration of the tokamak. The appearance of surfaces coated with protective thin (50–200 nm) amorphous hydrogenated carbonaceous layers (a-C:H) is presented in Fig. 1(b). Actively pumped limiters made of graphite were installed: Advanced Limiter Test (ALT-I) in a single location was then replaced by ALT-II in a form of a toroidal belt limiter located on the low field side at 45° below the equatorial plane. It was composed of eight blades with a total of 224 shaped fine grain isotropic graphite (Toyo Tanso IG 430U) tiles (shown in Fig. 1(c)). In consecutive years a bumper limiter was added: a belt of graphite tiles on the high field side, Fig. 1(d). During the next major wall upgrade in year 2003, a dynamic ergodic divertor (DED) was implemented [1,11]. This was associated with the necessity of installing a divertor shield, which resulted in a vast extension of the inner bumper limiter, shown in Fig. 1(e) and (f), acting as divertor target plates.

## 2.2. Transfer systems for test limiters and probes

A list of diagnostic tools for plasma edge and wall erosion diagnosis stretches from optical spectroscopy (passive and active), mass spectrometry, thermocouples, electrical instruments (Langmuir, retarding field analyser-RFA) to various

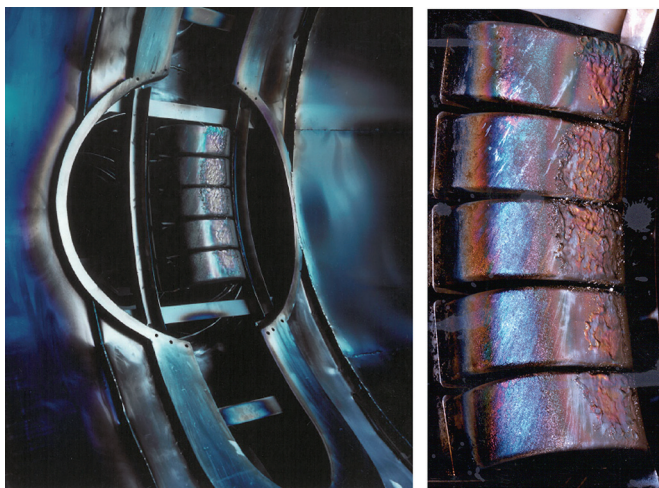

Fig. 2. Stainless steel main poloidal limiter used in TEXTOR in the first phase of operation in eighties of the 20th century. Melt zones were formed.

erosion–deposition probes (EDP) called in the following wall probes. In principle, the term “probe” denotes nearly every piece that can be retrieved from a tokamak after a short exposure (seconds) or a long-term campaign (many hours of plasma operation). It may be a source of a certain type of valuable information, provided that the history of exposure is well known.

The major goal in using wall probes is to determine erosion and deposition processes occurring at various surfaces subjected to plasmas. Experimental procedures comprise the exposure of material probes to plasma edge, in-situ diagnostic with spectroscopy and thermography methods followed by ex-situ examination of the exposed materials. Methods used in surface analysis are briefly addressed in Section 4. *Conditio sine qua non* for conclusive erosion–deposition studies is availability of versatile facilities enabling short- and long-term exposure of wall probes, i.e. transfer systems.

TEXTOR was equipped with three transfer systems: two so-called limiter locks (LL1 and LL3) located respectively at the bottom and the top of the vessel and a reciprocating probe (RP) system at the equatorial position on the low field side. Their location is presented schematically in Fig. 3. Observation of the probe was ensured either on the opposite axial direction or under perpendicular line-of-sight. Fig. 4 shows a general idea of the experimental set-up: a hemi-spherical (mushroom-shaped) test limiter located on a holder enabling rotation and linear movement to allow precise radial positioning inside the scrape-off layer (SOL) plasma up to the last-closed flux surface (LCFS) determined by the ALT-II or even deeper in the plasma converting the test limiter to the main limiter of plasmas, e.g. in power load studies of dedicated PFM such as tungsten. The exposed specimen could be actively cooled or actively pre-heated up to 750 K. A gas inlet system in the locks allowed for puffing of volatile compounds through a limiter. Local passive or active spectroscopy [14] and thermal (pyrometry, thermocouples) measurements ensured proper in-situ diagnosis of plasma composition and temperature control. Drawings in Fig. 5 give insight into the system for local optical diagnosis of the limiter. Large flexibility in operation of the manipulators in the limiter locks together with the optimised port-focused diagnostic created solid basis for a vigorous program aimed at testing of materials under tokamak conditions.

The probe system is composed of a transfer tube and bellows, drives for linear motion and rotation, probe exchange chamber with an ultra-high vacuum (UHV) window, pumping units and a gate valve. The first transfer system for a collector probe was built in 1980's and it came to operation in 1983 [15]. In the following years several components were modified but the location in the torus hall and basic principles of the operation remained unchanged. Progress in science and technology and also the implementation of DED called for a modification of that apparatus, because several ports were to be given to feedthroughs for coils of the ergodic divertor. It led to an idea of a multi-user probe facility, i.e. to the development of a system where various probe heads (electrical and collector) could be mounted and exposed to plasma [16]. Fig. 6 shows a general appearance of that assembly, whereas a

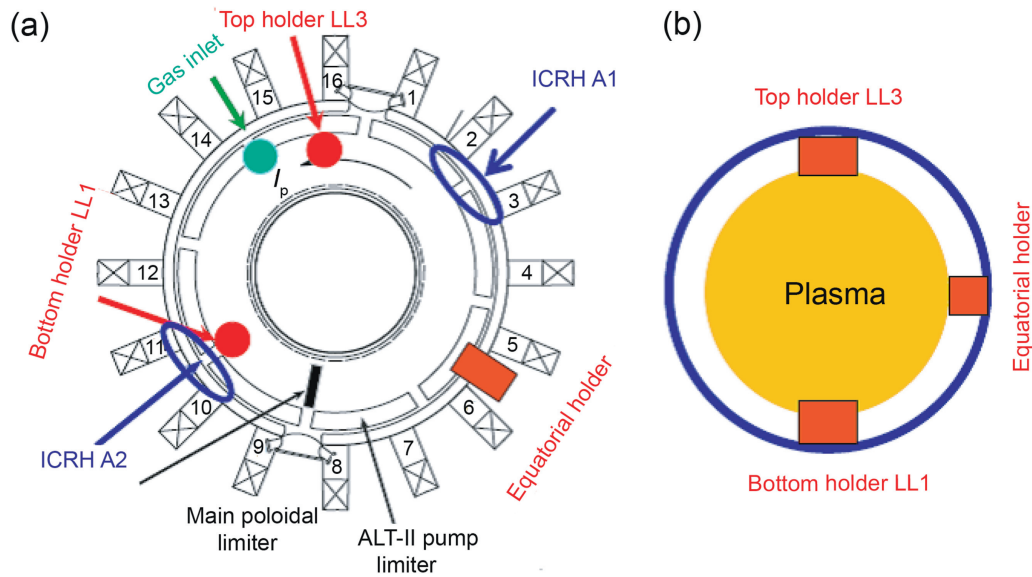

Fig. 3. (a) Top and (b) side view of TEXTOR showing the location of transfer systems (probe holders), ICRF antennae and gas inlet.

schematic drawing in Fig. 7 explains the probe location with respect to the torus. Three computerised numerical control (CNC) drives allowed a variety of operation modes: (i) slow linear motion used for placing probes in a stand-by position in the SOL; (ii) fast reciprocation enabling short term exposures in the edge plasma; (iii) synchronised rotation for either time-resolved measurements of particle fluxes or the exposure of multiple collector probes. Combination of several operation modes and their simultaneous application could be pre-programmed when necessary. The most important technical details of the system are summarised in Table 1. Several probe heads were designed and constructed: Mach, Langmuir (multi-

pin) and a large variety of surface collectors. A unified coupling interface equipped with electric connectors enabling unmistakable mounting and fast exchange of the probes heads. This is shown in Figs. 7 and 8 presenting the general view and details of the exchange interface, respectively. Elements of Fig. 9 illustrate two situations: (a) the locking system is pressed against the base plate, thus fixing the probe position on the carrier for an exposure; (b) the lock is retracted (open) for the probe release and exchange. The interface together with an efficient pumping system equipped with a pre-cooled cryogenic panel enabled the exchange of probe heads in less than 2 h. This was a very important feature of the facility making the measurements with various probe heads possible on a single operation day. A drawing in Fig. 10 shows the assembled system with a collector probe. With the experience from TEXTOR, a similar probe assembly is being developed for Wendelstein 7-X (W7-X) stellarator [17].

### 3. Erosion–deposition probes and their applications

Wall probes belong to two basic categories: passive and instrumented tools. The latter term denotes various types of probes and also PFC tiles equipped for instance with a gas inlet system for the localized and active modification of the plasma edge composition and the material surface. Active modification is also realized by laser pulses to ablate species from the tested material surface. Over the years, the transfer systems have been used to carry out: (i) the performance test of high-Z metals [4–8,18–44] and composite materials [37,45–51] considered at that time as candidates for PFC in next-step devices; (ii) material transport studies [26,52–54], (iii) laser- [42,44–46] and gas puff-assisted [54–60] modification of surfaces and plasma edge. Secondly, results of experiments performed under well diagnosed (i.e. controlled) conditions have provided most valuable input for advanced modelling and thus allowed for insight into erosion and

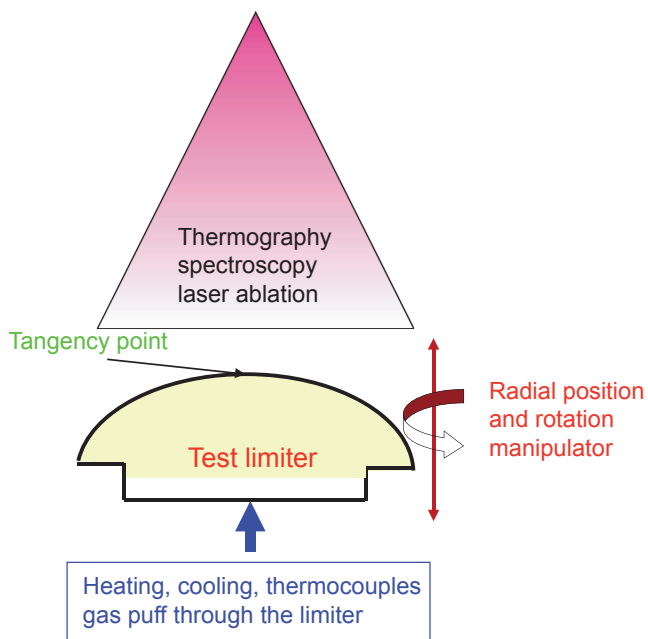

Fig. 4. A scheme of a set-up for experiments with test limiters and probes in limiter locks.



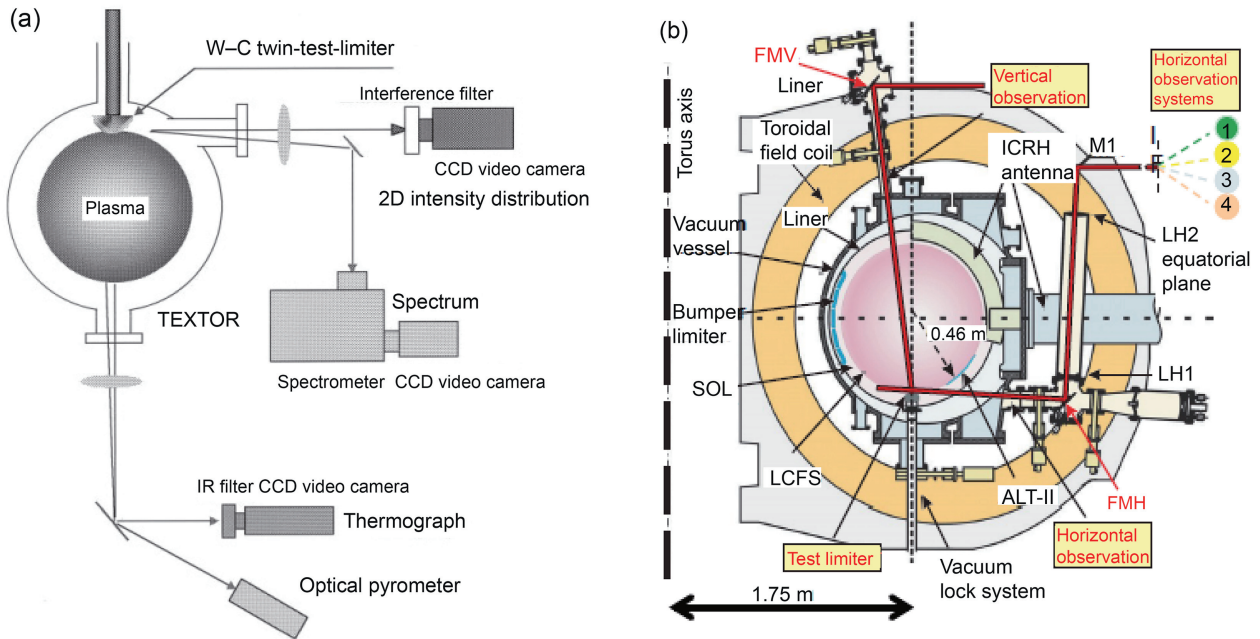

Fig. 5. Diagnostic systems for test limiters: schemes of (a) top limiter and (b) bottom limiter diagnosis.

deposition processes [14,31–36,40,42,54], in particular recycling under different wall conditions and with different PFM like carbon and tungsten, basic processes (e.g. ion reflection) and material mixing in the presence of several wall materials,

retention in carbon and high-Z metals (Mo, W, Ta), re-erosion efficiency of co-deposits. As a result of that integrated experimental and modelling approach, the understanding and assessment of behaviour of various materials and their impact on the tokamak operation have been improved, e.g. pointing to the prevalence of tungsten over other heavy metals. All activities in materials testing were always directed towards addressing crucial points in PWI for a future reactor-class device, e.g. ITER: selection of an optimal wall material.

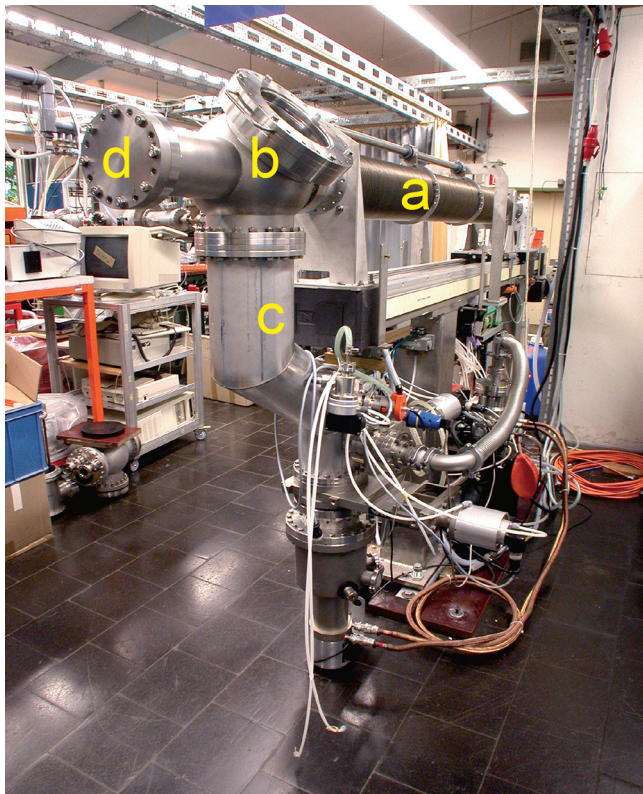

Fig. 6. A general view of the probe transfer system in the assembly hall: a – probe transfer tube with bellows, b – probe exchange chamber, c – pumping system, d – port for connection to TEXTOR; the port is flange-blinded for testing before installation at the tokamak.

### 3.1. Test limiters

There were tens of test limiters designed, manufactured and exposed. Limiters were tailored to fit specific purpose. Presentation of all of them is neither intended nor planned here. Therefore, the presentation is structured in a topic-oriented manner.

#### 3.1.1. High-Z metals

For many years most devices were operated with carbon walls because of excellent power handling capabilities of graphite and, especially, carbon fibre composites (CFC). However, chemical erosion of carbon leading to hydrocarbon formation and resulting in pronounced fuel retention (tritium inventory) is the driving force for studies of alternative first wall materials [2,3]. High-Z metals, e.g. tungsten and molybdenum, of high melting point and high threshold energy for sputtering by hydrogen isotopes have been extensively examined at TEXTOR since 1992 in a close co-operation with Japanese partners from Osaka University, Nagoya University and Kyushu University. Fig. 11(a) shows a mushroom-shaped tungsten mono-block limiter exposed for around 600 s of plasma operation, i.e. some 100 pulses. The power deposited on such limiters reaches up to 7% of the total plasma power

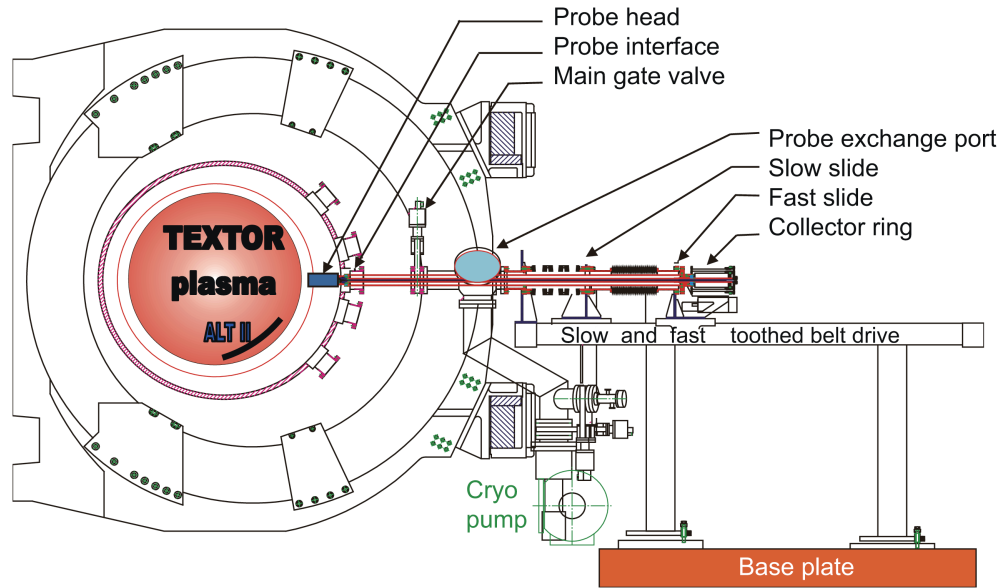

Fig. 7. Probe assembly at the TEXTOR tokamak.

during the exposure inside LCFS. Fig. 11(b) shows a temperature profile on the limiter surface. The erosion of tungsten and the impact on plasma performance could be determined, especially the release of high-Z impurity species and their transport under limiter conditions.

Table 1  
Properties of the fast probe system.

<b>Location</b>	Equatorial plane at the low field side 45° poloidally from the toroidal belt pump limiter (ALT II)
<b>Length</b>	3.4 m
<b>Slow drive</b> CNC stepping motor Toothed belt slide	Linear transfer for positioning in the SOL Maximum speed 0.3 m/s Covered range 1.5 m
<b>Fast drive</b> CNC stepping motor Toothed belt slide	Fast reciprocation into the plasma edge Maximum speed: 3 m/s tested in laboratory, 1 m/s used in tokamak Maximum acceleration 50 m/s <sup>2</sup> Covered range 17 cm
<b>Rotation</b> CNC stepping motor Toothed belt transmission	For positioning and exposure of surface collector probes Single step reproducibility 0.36° Maximum step frequency 3000 s <sup>-1</sup> Rotation frequency 3 Hz Rotary direction: forward, reverse
<b>Electric connectors</b>	20 pins including 4 for internal heating of probe heads up to 300 °C
<b>Pumping system</b>	Turbomolecular, rotary and cryo pumps
<b>Probe exchange time</b>	Min. 2 h due to a pre-cooled cryo panel and fast exchange interface
<b>Control &amp; Trigger</b>	SIMATIC S7, free programmable trigger, CAMAC TEXTOR timing
<b>Data acquisition</b>	CAMAC, Kinetics System logger

Another lesson learnt from the W-limiter testing is related to the necessity of careful operation with PFC made of brittle metals: pre-heating the mono-blocks to temperature of around 600–700 K, i.e. above the brittle-to-ductile transition temperature in order to avoid material cracking by thermal shock under high heat loads. A cracked limiter is in Fig. 12. This severe damage to the mono-block was caused by a disruption, while the limiter was not pre-heated (failure of the limiter heating system) to temperature of around 600–700 K, i.e. above the brittle-to-ductile transition temperature. This type of damage is not expected in a quiescent reactor operation (e.g. ITER) when actively-cooled tungsten components are heated up in operation to a steady high temperature level. However, cracking cannot be excluded in case of thermal shock on a still cold divertor or when a failure to the target cooling system would occur.

Special attention was given to tungsten melting experiments [6,17,37,61–64]. It is exemplified in Fig. 13 by a scheme

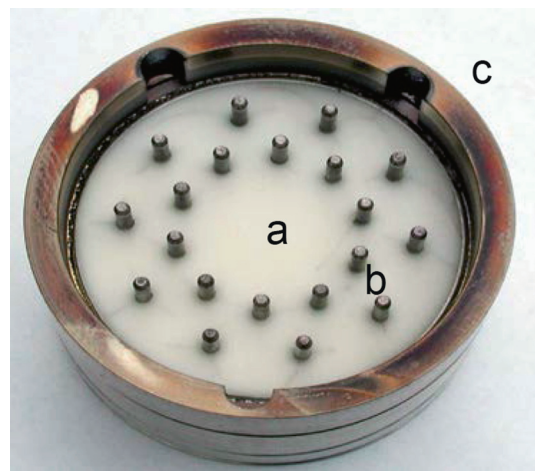

Fig. 8. Vacuum-tight interface for a fast exchange of probes: a – aluminium oxide ceramic, b – titanium electrical connectors, c – assembly ring with slots for unmistakable probe mounting. Precision of the unit is better than 0.1 mm and 0.36°.

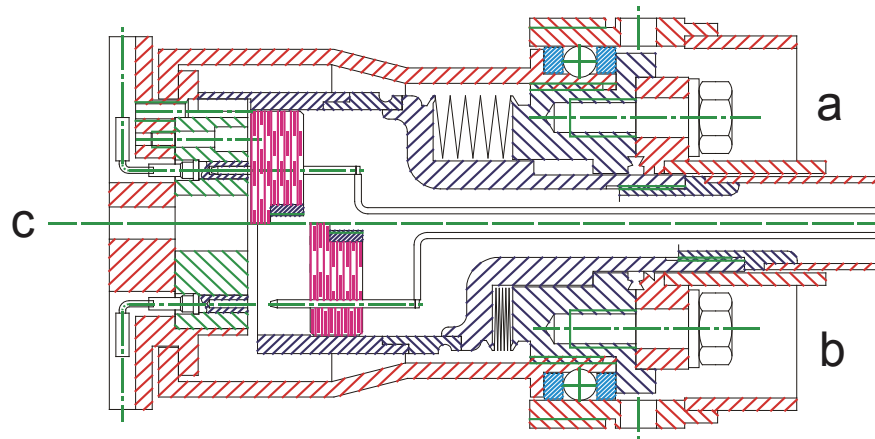

Fig. 9. Details of the probe exchange interface: a – fixed lock position for the probe operation, b – retracted lock for the probe release and exchange, c – exchangeable base plate.

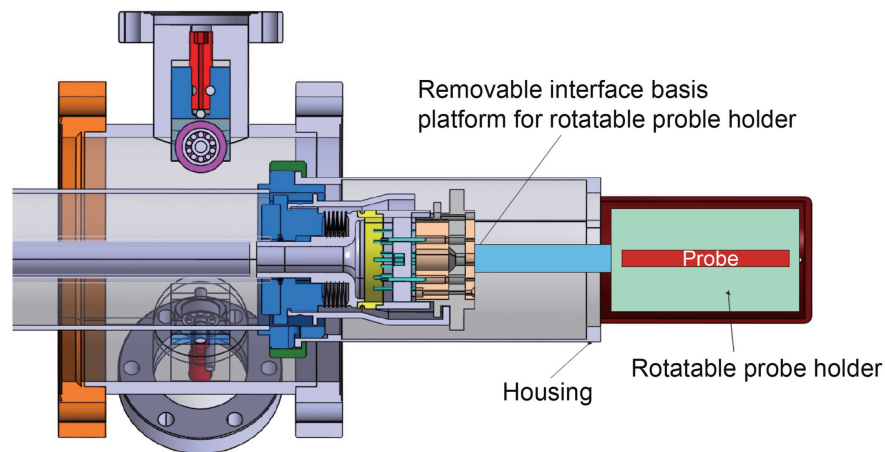

Fig. 10. A probe head installed on the transfer system.

showing the exposure of a roof-shaped limiter with a tungsten plate. As the thermo-mechanical durability and integrity of tungsten components is of crucial importance for ITER, castellated W limiters with a macro-brush structure, see Fig. 14, have also been tested [6,62,63]. It should be stressed that these were either both mono-blocks like the one in Fig. 14(a) or constructions composed of detachable plates, as shown in Fig. 14(b) and (c). The latter was crucial for detailed characterization of material re-deposition, material mixing and fuel inventory in the grooves, as it was an important target of the experimental program [63,65]. A number of experiments were performed with specially shaped castellated tiles in order to determine the relation between the tile shape (including the width of castellation) and the retention [66]. Accompanying modelling of resulting deposition inside the gaps of the castellation has been done with the Monte-Carlo code 3D-GAPS [67]. The issue of deposition in gaps [29] was also included in the dedicated program with so-called twin limiters described below.

### 3.1.2. Twin limiters

Fig. 15 shows an exposed twin limiter. It consists of two parts of the same geometry: one made of tungsten and the second of

graphite. Experiments were focused on direct comparison of materials' behaviour under nearly the same plasma conditions. Such similar exposure conditions of the two halves were ensured by rotating ( $180^\circ$ ) the limiter holder between two very similar discharges, i.e. during consecutive plasma pulses either side faces similar particle fluxes. The program has been concentrated on comparative studies of thermal response, particle recycling, fuel inventory and material mixing. Short (prompt re-deposition) and long range transport of tungsten could be assessed and fuel inventory in that material was determined: below  $1 \times 10^{15}$  D atoms/cm<sup>2</sup> retained in a thin surface layer only. This is significantly less fuel (orders of magnitude) than those stored in carbon and carbon-containing re-deposited layers. Detailed comparison of W and C behaviour is presented in Ref. [29]. It is also stressed that no blister formation had been identified in the plasma-exposed tungsten. A limiter made of tungsten and tantalum mono-blocks was also examined [39,40]. The erosion–deposition characteristics of the twin limiters have been reproduced by modelling with impurity and plasma-wall interaction code EDDY [68].

The comprehensive work program on high-Z metals carried out at TEXTOR and then under divertor conditions in ASDEX



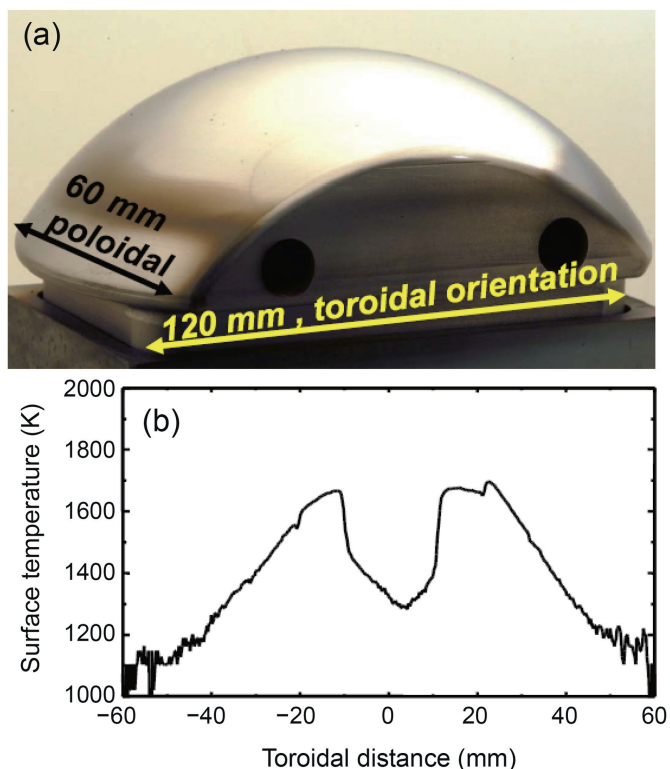

Fig. 11. (a) Bulk tungsten test limiter and (b) surface temperature measured during the limiter exposure. Toroidal distance equal “0 mm” corresponds to the top point on the limiter.

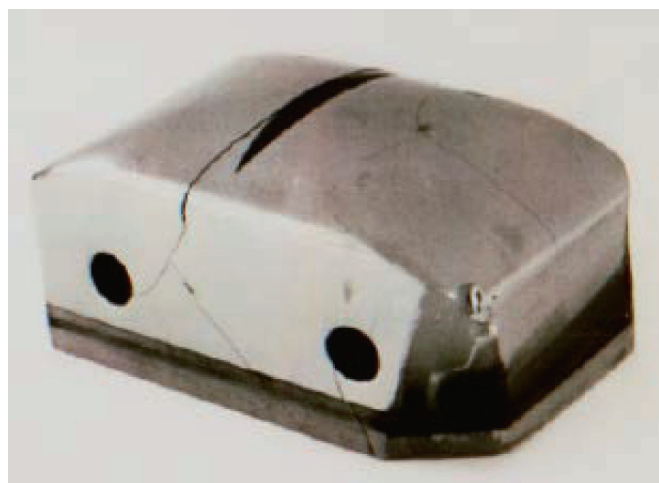

Fig. 12. Bulk tungsten test limiter cracked under high power loads because of the failure in the limiter pre-heating system.

Upgrade (AUG) has had a crucial impact on the entire fusion science and wall technology: operation with a full metal wall in AUG, change of the carbon PFC to tungsten and beryllium in the ITER-Like Wall Project at JET (JET-ILW). Eventually, it led to a time- and money-saving decision to start ITER operation from day one with the full tungsten divertor instead of using a divertor with target plates made of tungsten and CFC first and only to replace it with tungsten later.

### 3.1.3. Tests of carbon-based composites

The interest in carbon-based composites doped with boron, silicon or titanium is associated with an expected reduced rate of chemical erosion of such materials under the tokamak conditions. Lower erosion rate was observed under laboratory conditions in ion beam experiments. Limited testing had been carried out in some machines. At TEXTOR several types of materials were examined: Si-doped carbon fibre composite (NS31 produced by Snecma), titanium-doped graphite (RGTi) and  $B_4C$ -coating (170  $\mu\text{m}$ ) on copper or on stainless steel limiters.

A test limiter (NS31) was used to determine spectroscopically the release of impurities (e.g. C, Si, CD radicals). A reduced methane production was found in the Si-doped graphite when compared to a pure graphite limiter. Silicon evaporated from the surface at temperatures above 1500  $^{\circ}\text{C}$ . This led to an increase of Si concentration and total radiation losses from the plasma. Surface analysis showed the formation of micro-cracks and holes on the plasma exposed limiter surface [45]. These are obvious precursors not only of erosion but – more importantly – of material disintegration.

The exposures of boron carbide coatings on metals (Cu, steel), tested as candidate PFC for the W7-X stellarator, resulted in significant damage to the layers caused by unipolar arcing over the whole surface and melting in areas of the greatest power load [37,49–51]. The exposed limiter is shown in Fig. 16. As a consequence of that experiment which resulted in the damage of boron carbide coatings, it was decided not to use such materials for W7-X.

It should be stressed that composite materials, such as those mentioned above and many other candidates for PFC, have not been eventually used in fusion devices, because of significant property degradation. There are no plans for their application as PFC in future machines. This shows the important wall probes for material selection. The qualification process must comprise tests carried out under realistic conditions: particle fluxes, heat loads, etc.

### 3.1.4. Techniques based on gas puff and material ablation

Gas-puff to the plasma edge is realized using an inlet pipe connected to a calibrated volume. This has been used for injection of deuterated silane ( $\text{SiD}_4$ ) [52] or tri-methylborane ( $\text{B}(\text{CH}_3)_3$ ) through a test limiter. The aim was to explore the possibility and efficiency of in-situ repair of wall protective films [69].

The same injection technique was applied to introduce C-13 labelled methane as a tracer in studies of carbon transport [14,53–56]. Ex-situ surface analyses of the exposed tiles and probes allowed for the selective and quantitative determination of the rare isotope migration in a carbon-wall machine. Natural abundance of  $^{13}\text{C}$  amounts to  $\sim 1\%$ , therefore 100%  $^{13}\text{CH}_4$  was used. Images in Fig. 17 show respectively a roof-shaped test limiter with an inlet system and a top plate with the deposition pattern after injection of  $^{13}\text{C}$ -labelled methane applied as a marker for carbon migration studies. In-situ viewing of the layer growth followed by ex-situ surface analysis of the plate and intense modelling with the 3D

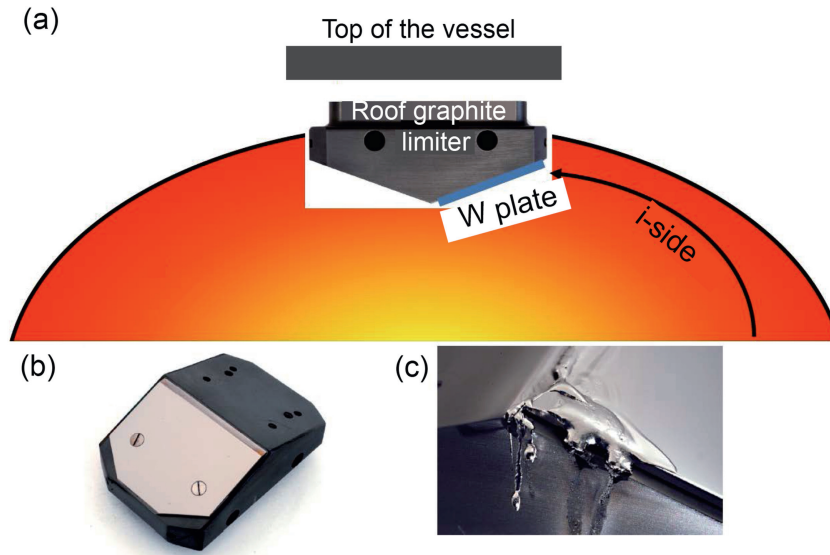

Fig. 13. Tungsten melting experiment: (a) experimental set-up; (b) test limiter before the exposure and (c) after.

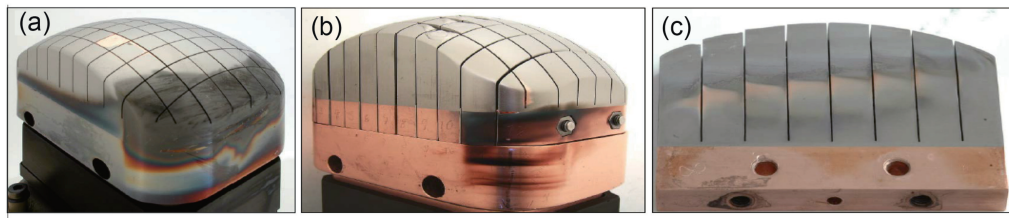

Fig. 14. Castellated tungsten test limiters after exposure to the plasma in TEXTOR: (a) castellated mono-block; (b) limiter composed of detachable plates; and (c) a single segment of that limiter.

impurity transport and plasma-wall interaction code ERO resulted in the determination of very high in-situ re-erosion rates of re-deposited carbon films, which are up to a factor of 30 larger than the erosion of bulk graphite [70,71]. Further injection experiments studying the influence of ion impact energy (applying biasing) and deposition flux (by changing the injection rate) on the re-erosion of re-deposits have been performed together with ERO modelling [72]. This helped understanding the overall migration scenario of carbon,

especially long- and short-range transport and, eventually, its role in fuel inventory. The system was used on many other occasions also including injection with high-Z tracers such as  $WF_6$  [58,59] and  $MoF_6$  [59,60]. The experiment [58] gave the first direct and clear proof of the prompt re-deposition model

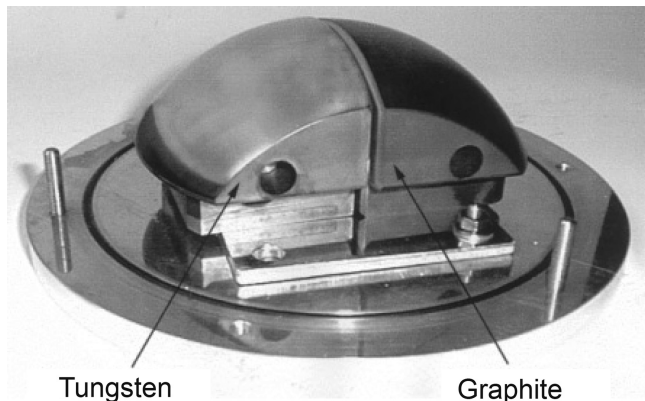

Fig. 15. Graphite–tungsten twin limiter after exposure in TEXTOR.



Fig. 16.  $B_4C$ -coated test limiter damaged by arcing and melting during the exposure to plasma.



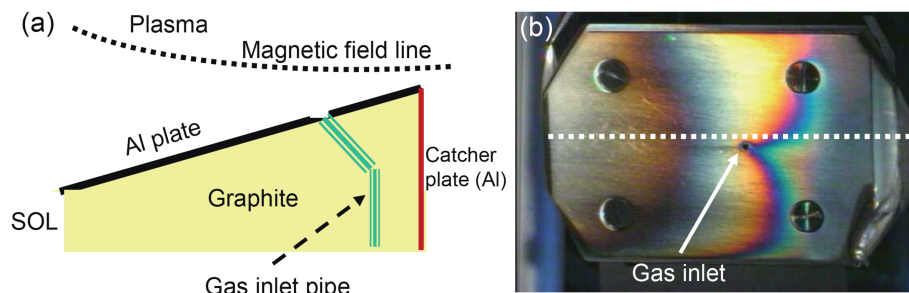

Fig. 17. (a) Roof-like limiter with the gas inlet system and (b) the deposition pattern of the C-13 and C-12 following  $^{13}\text{CH}_4$  injection during plasma discharges. The line of analysis is indicated by white dots.

predicted by Naujoks [73]. Experimental data on W and Mo transport are currently a subject of broad modelling activities; early results have been published in Ref. [60]. In general, the tracer technique allowed for the assessment of long- and short-range transport of carbon and other species in fusion devices.

Experimental procedures first developed at TEXTOR have then been used in JET [74,75], DIII-D [76] and AUG tokamaks [77]. In recent years studies of nitrogen retention in PFC were initiated with  $^{15}\text{N}$  as a marker in material migration studies [58–60,78–80]. Nitrogen ( $^{14}\text{N}_2$ ) is used for plasma edge cooling and its long residence time in a tokamak had been observed also during ex-situ studies of PFC. Experiments with a rare nitrogen isotope ( $^{15}\text{N}$  natural abundance 0.37% versus 99.63% of  $^{14}\text{N}$ ) were performed to avoid speculations about the nitrogen origin in ex-situ analysed material: retention in a tokamak or sorption from air during the transfer and storage of specimens to a surface analysis station. The results from TEXTOR [78,79] and then from AUG [80] have confirmed the long-term retention in the range from 4% to 30% dependent on the machine wall composition: 15%–30% in carbon wall TEXTOR and 4%–10% in AUG with W coatings on graphite tiles.

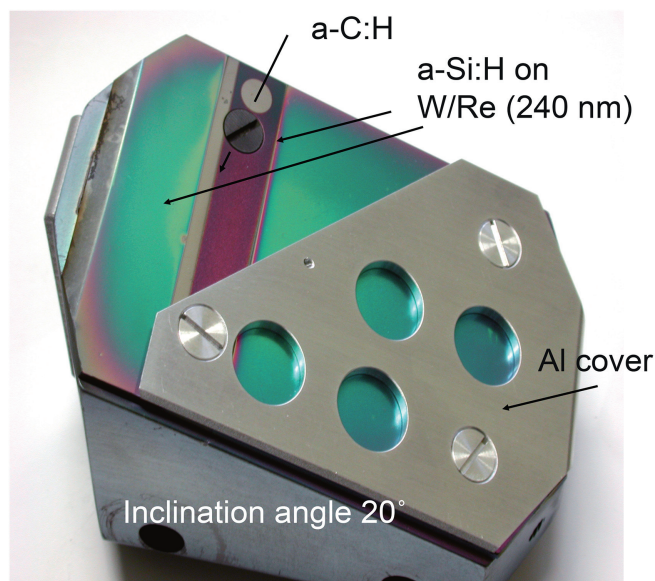

Fig. 18. Roof-like limiter coated with thin films as tracers of material erosion and transport.

The roof-like limiter has also been applied for exposures of probes pre-coated with a defined amount of tungsten, silicon, carbon and boron. Using the probe shown in Fig. 18 one could determine the erosion and transport of those elements, especially the transport to shadowed area.

Material ablation from surfaces of test probes by laser pulses is predominantly used to introduce a given amount of material to the plasma. This is to study plasma parameters and material transport. In fusion technology, the laser-assisted ablation was considered as a method for fuel removal and decomposition of re-deposited films. First-ever in-situ tests of that kind were performed in TEXTOR [44] and they involved desorption of hydrogen accompanied by the removal of a thin (100 nm) hydrogenated C-B layer pre-deposited on the tungsten limiter. However, drawbacks of this approach must also be stressed: generation of dust upon disintegration of the irradiated carbon-rich co-deposits, as it was documented in detail by laboratory tests [81].

### 3.1.5. Material re-deposition and fuel retention

In carbon wall devices studies of material erosion and re-deposition are strongly focused on the growth rate of co-deposited layers containing hydrogenated carbon films. The aim is to determine the layer thickness and fuel retention, i.e. to assess tritium inventory in a reactor-class machine. Exposures of tiles under well diagnosed and defined conditions allowed for in-situ measurements of the surface morphology by means of colorimetry technique [82]. The layer thickness was also determined with microscopy and ion beam methods. The growth rate of fuel containing carbon deposits on the main PFC in TEXTOR was around 3 nm/s. Similar values were also measured in other carbon-wall tokamaks thus indicated both unacceptably high erosion-rate of carbon wall and fuel inventory. These facts motivated research on high-Z metals as wall materials; it was addressed earlier in Sections 3.1.1 and 3.1.2.

Fuel retention in various materials can be compared when the substrates are exposed under identical plasma conditions. The large size of the limiter lock manipulator enabled such comparative studies. A number of substrates (graphite, carbon fibre, Si-C composites) were mounted on a specially designed holder and simultaneously exposed to the SOL plasma [82,83]. Using the same approach the retention of nitrogen-15 tracer in tungsten and carbon was investigated [78]. The assembly of the experimental set-up is shown in Fig. 19.



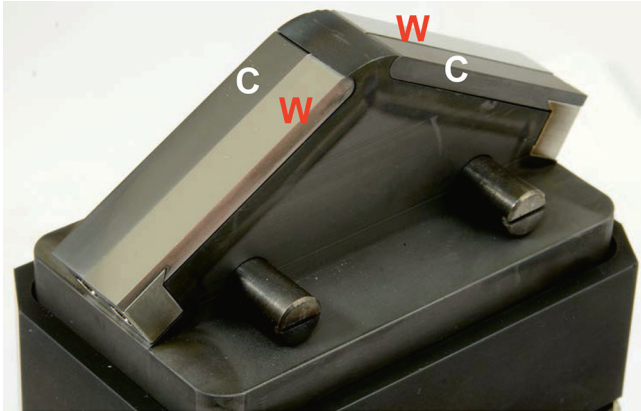

Fig. 19. Test limiter assembly for comparative material studies.

### 3.1.6. First mirror test

First mirrors will be crucial plasma-facing elements of optical diagnostic systems in ITER. Mirror surfaces will undergo modification caused by erosion and re-deposition processes. As a consequence, the mirror performance may be changed and may deteriorate, i.e. reduced reflectivity. The limited access to in-vessel components of ITER called for testing the mirror materials in present day devices in order to gather information on the material damage and degradation of mirror performance. A dedicated experimental program at TEXTOR [84–86] exploited the flexibility of transfer systems for exposures of relevant mirror materials, e.g. molybdenum and stainless steel, under various plasma conditions. Exposures were carried out at different radial positions and, therefore, both erosion and depositions effects on the mirrors could be assessed. In erosion-dominated areas the total reflectivity was maintained or even increased (removal of Mo oxides layer). In the deposition-dominated zone optical properties were significantly degraded by the formation of carbon-rich deposits. Experiments at TEXTOR were followed by mirror tests in many tokamaks: JET, DIII-D, NSTX, Tore-Supra, TCV, T-10 [86].

### 3.2. Reciprocating surface collector probe: examples of application

Collector probe systems were installed in most tokamaks which started operation in the 1980's. As already mentioned earlier, at TEXTOR, the system was constructed in 1982 and came to operation in the next year [15]. Since then, with several modifications [16,82] the diagnostics has faithfully accompanied the development of TEXTOR bringing information on ion transport in the SOL under different experimental situations, including the change of wall composition [88–93], plasma parameters [88,89,94], auxiliary heating [87,88,95], high-Z material testing [3,4,95]. As mentioned in Paragraph 2.2, in nineties the probe system was converted to a user facility where also different heads of electrical probes could be installed and operated. Details about those probes can be found in [96–99]. In the following we introduce different collector probes and probe head assemblies and, afterwards,

focus on metal fluxes at different wall conditions and testing of high-Z metals.

Images in Fig. 20 (a) and (b) show two probe heads with a housings made fully of graphite or refractory metal, respectively. Slits face the ion and electron drift directions. In the case of the graphite housing the slit width could be adjusted (1–4 mm), while the slit in the angled top cover allowed measurements of radial fluxes. A cylindrical holder (60 mm long and 50 mm in diameter) with grooves for 10 samples allowed for stationary exposure (full discharge or a fraction of it) to five different experimental conditions. For time-resolved measurement a simple cylindrical probe was used, as shown in Fig. 21. Usually graphite substrates were used as particle collectors and their efficiency for collection of species had also been determined [100]. For instance, aluminium collectors were used in studies of carbon fluxes.

Following the exposure, the probe was retracted from the machine, dismantled and transported to the surface analysis station (SAS) for qualitative and quantitative analyses of the species deposited [15,88–95,100] and the structure of deposits [101–103]. This was achieved by a combination of complementary methods offering different spatial and depth resolution. In most cases the study was carried by ion beam analysis (IBA), especially Rutherford backscattering spectroscopy (RBS) and nuclear reaction analysis (NRA). Details on analysis are presented in Section 4.

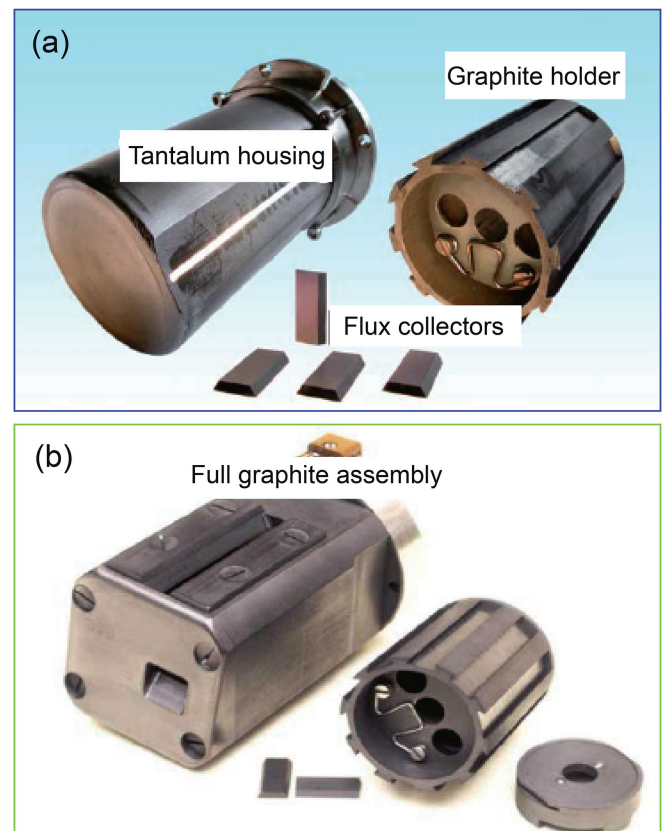

Fig. 20. Components of the collector probe heads: (a) an assembly with a metal housing; (b) complete graphite assembly.

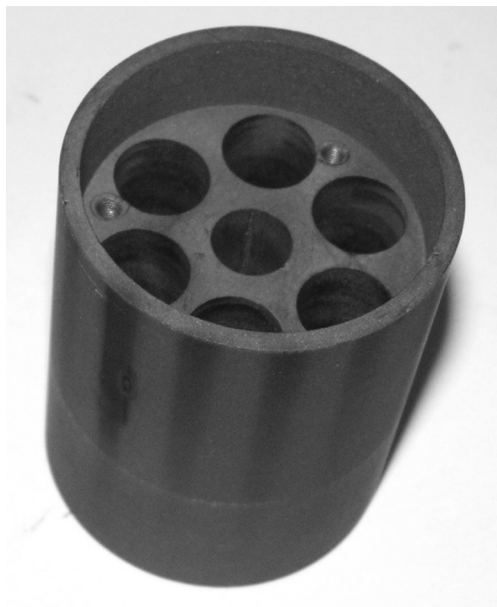

Fig. 21. Graphite collector probe for time-resolved or time-integrated measurements of particle deposition rates in the SOL. The probe shown above was in the time-integrated mode to several discharges; deposition traces are perceived.

Collector probe, as every diagnostic, has advantages and limitations. The main advantage is the discrimination between different species transported in the SOL. It is probably the only diagnostic capable of tracing different species in that region. Sensitive and selective IBA measurements give areal concentrations of various species. When dividing these values by the probe exposure time one obtained effective deposition rates corresponding to particle fluxes in the SOL. The term “effective rates” denotes the net effect of deposition and re-erosion of deposited species. For medium- and high-Z metals the sticking of such species to light targets (e.g. graphite) is close to one, therefore the deposition rates reflect actual fluxes. For deuterium, boron and carbon, the re-erosion by sputtering, chemical erosion and, in the case of D and C, thermal desorption of  $C_xD_y$  had to be taken into account. Highly reproducible results are obtained for probes exposed to similar discharges, whereas any changes in plasma parameters are sensitively reflected by the change of the deposition rates. Moreover, the probe traces radial distribution of particles in abroad region of the SOL: from 5 mm to 65 mm deep in the limiter shadow. The major drawback of the probe is that its surface is studied by ex-situ techniques and in the transported to SAS it is in contact with air. For that reason incident fluxes of deuterium and oxygen cannot be determined because of possible desorption and isotope exchange with hydrogen in the case of deuterium. The oxygen content may be changed by the incorporation (absorption) of atmospheric oxygen. Several issues of that kind have been addressed in Refs. [88,104,105]. The method is also relatively slow because of long time needed (minimum 6 h) between the exposure and the analysis. However, this experimental procedure does not change the

content of other species: B, C, Si, metals. In summary, the probe measurements in the SOL plasma are complementary to spectroscopic observations in the plasma edge.

Plots in Fig. 22 show the temporal evolution of metal (Inconel components: Ni, Fe, Cr) deposition rates on probes exposed under different wall conditions: with all metal surrounding and after wall conditioning by carbonization, boronization and siliconization. The probes, like the one in Fig. 21) were exposed in a time-resolved mode, i.e. were rotated synchronically during the discharge. The results clearly demonstrate the role of wall conditioning, i.e. the deposition even of a thin protective layer reduces the erosion of heavy species from the wall and their influx to plasma. The results indicate that the initial effectiveness (i.e. during the first discharges after wall conditioning) of boron- and silicon-based coatings in wall protection is similar.

Fig. 23 shows the deposition rates of deuterium, oxygen, Inconel alloy components and molybdenum measured 35 mm deep in the SOL. Probe exposures were performed during four discharges (lasting 4 s each) in the experiment with a carbonized molybdenum limiter. The aim was to determine the erosion of the carbonised layer and the influx of Mo to plasma. The evolution of fluxes follows the discharge characteristics (i.e. density profiles) with maximum values observed during the flat top phase. The plots also prove that the deposition process takes place, though with the changing intensity, during the whole discharge period and not only during some particular phases. For the three discharges with the pre-carbonized Mo limiter, the deposition profiles of D, O and Inconel metals remain nearly unchanged, whereas the amounts of Mo transported in the SOL increase steadily from shot to shot. It clearly indicates the advancing erosion of the carbonized layer from the limiter surface and, as a consequence, the exposure of increasing Mo surface area to the plasma. Smaller, but not

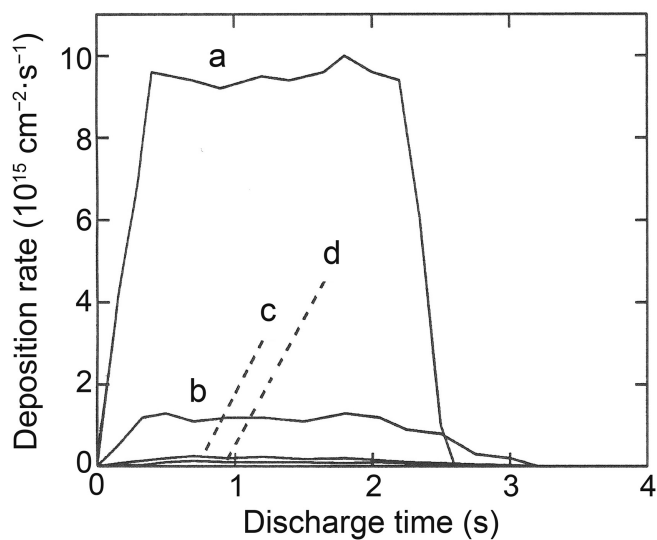

Fig. 22. Deposition rates of metals (NI + Cr + Fe) under different wall conditions as a function of the discharge time at TEXTOR: a – “all metal”, i.e. stainless steel limiters and Inconel liner; b – “all carbon”, i.e. carbonized liner and graphite limiters; c – boronized; d – siliconized.

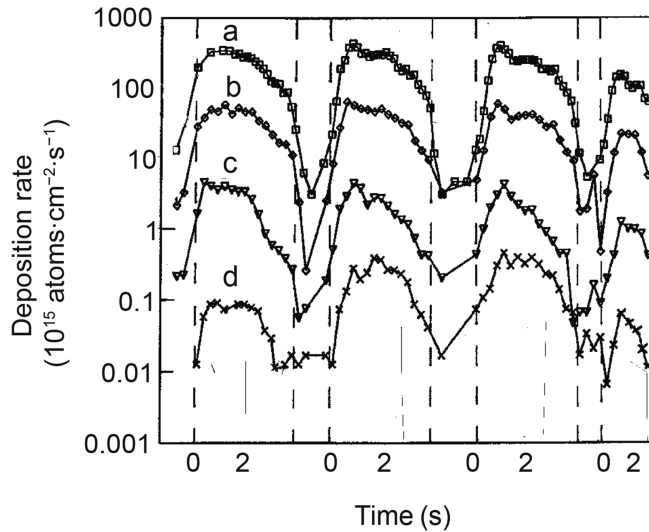

Fig. 23. Deposition rates of a – deuterium, b – oxygen; c – Inconel alloy component, d – molybdenum on the probe as a function of the discharge time during four discharges lasting around 4 s each. Discharge time (0 s; 2 s) is marked on X-axis.

negligible, molybdenum fluxes are observed even after the withdrawal of the metal limiter (the fourth discharge). This is mostly attributed to the re-erosion and transport of Mo species distributed in the torus during the preceding shots. Taking into account results of probe analyses together with literature data on physical sputtering and chemical erosion yields for D and impurity species in the machine, the recession rate of the carbonized film and the erosion rate of molybdenum from the limiter could be estimated:  $6 \times 10^{16} \text{ cm}^{-2}$  and  $1.2 \times 10^{16} \text{ cm}^{-2}$ , respectively.

Fig. 24 shows Rutherford backscattering spectra recorded during an experiment with a tungsten test limiter which was immersed 1 cm deep into the plasma. The probe was exposed

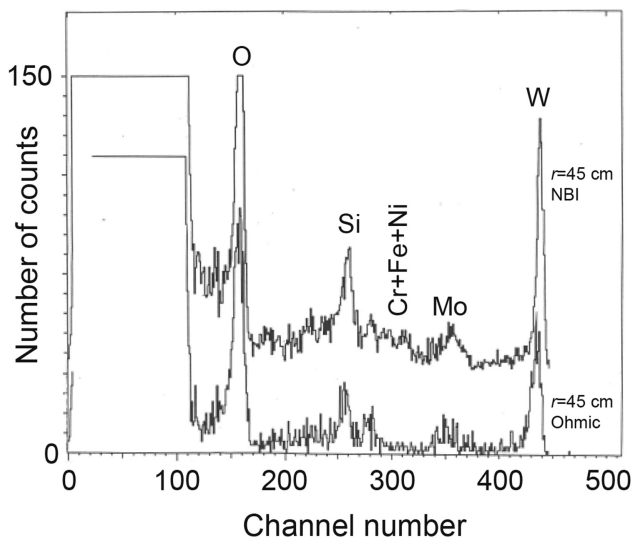

Fig. 24. Rutherford backscattering spectra of deposits collected on the probes during ohmically (lower) and NBI heated (upper) pulses in the presence of the tungsten limiter.

under plasma heating conditions: Ohmic and with neutral beam injection (NBI). One may perceive that the deposition rates of various species are greater for the NBI heated discharge when particle energies in the plasma were increased. It led to enhanced sputtering and, eventually, to greater fluxes of impurity species in the SOL.

#### 4. Analysis of plasma-exposed materials

In-situ spectroscopy measurements and visual inspection of the exposed PFC and probes must be finally examined by ex-situ material research techniques. The primary interest in analysis is focused on the retention of fuel species (D and T) and on properties of the first wall materials. The aim is to obtain a comprehensive overview of the migration pattern, not just to have even a large number of isolated finding (e.g. measured points). This requires both a properly selected set of wall components (i.e. PFC tiles), and a set of various wall probes, instrumented tiles, material transport tracers, etc. Comprehensive analysis also requires a network of specialised laboratories with expertise in studies of reactor materials, advanced apparatus and capabilities of handling such materials.

##### 4.1. Species to be analyzed

The analyses are carried out for all types of species (materials, elements and their isotopes) which were deliberately or accidentally installed, inserted or introduced to the torus.

- Hydrogen isotopes: H, D, T.
- Helium isotopes:  $^4\text{He}$  being a fusion product or used for wall conditioning,  $^3\text{He}$  used for heating with radio frequency (RF) waves.
- Major PFC materials: beryllium and tungsten and carbon.
- Constituents of the vacuum vessel wall: Inconel<sup>®</sup> alloy and/or stainless steel: Fe, Ni, Cr, Mo, Nb, Hf, W.
- Composite materials tested as candidates for PFC: C-B, C-Si, C-Ti.
- Elements used for wall conditioning by evaporation or plasma-assisted film deposition: Li, Be, B, C, Si.
- Gases seeded for plasma edge cooling:  $\text{N}_2$ , Ne, Ar, Xe
- Various markers for material transport studies: e.g.  $^{10}\text{Be}$ ,  $^{10}\text{B}$ ,  $^{11}\text{B}$ ,  $^{13}\text{C}$ ,  $^{15}\text{N}$ ,  $^{18}\text{O}$ ,  $^{21}\text{Ne}$ , F from gaseous high-Z metal carriers  $\text{WF}_6$  or  $\text{MoF}_6$ , laser-ablated markers (Hf) and components of sandwich-type marker tiles: B, Re, Ta.

##### 4.2. Methods for probe analyses

Nearly fifty different techniques have been used to respond to such comprehensive research needs, to obtain most fundamental and specific information on targets exposed to plasma. The list is still growing to meet new challenges. The aim of analysis is to determine material morphology and its changes under plasma impact: structure (surface and bulk) and composition (elemental, isotopic, chemical). One has to select a proper set of tools to solve a given problem, in other words: a



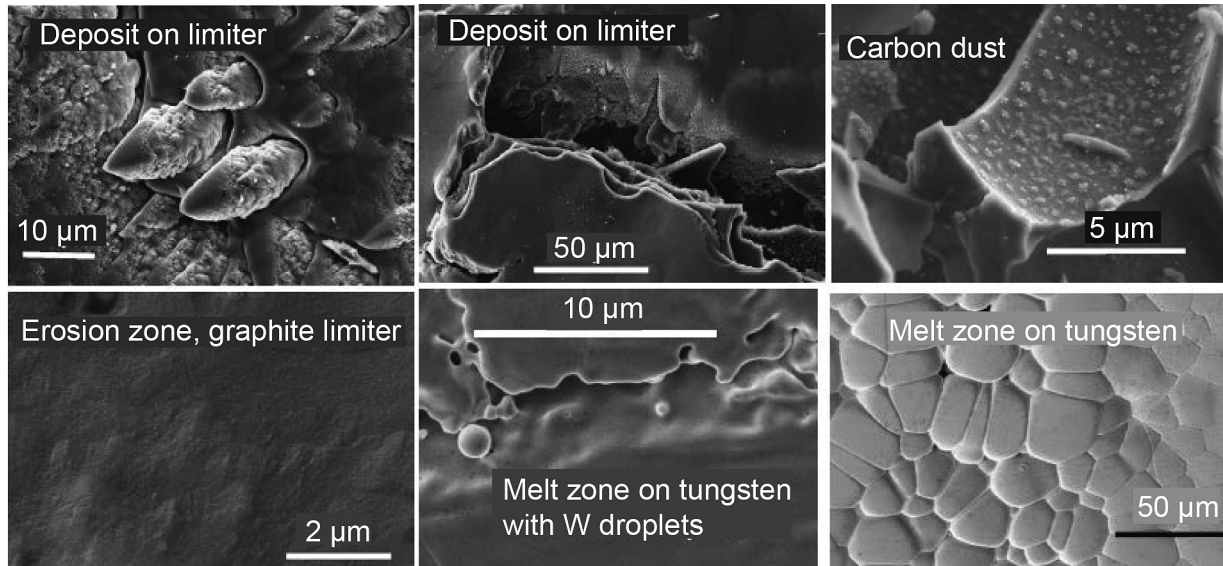

Fig. 25. Electron micrographs of carbon deposits on plasma-facing component; eroded graphite surface of a limiter and metal splash on PFC and the recrystallized melt zone on a tungsten test limiter. Author of micrographs: E. Wessel (FZJ, Germany).

set of most efficient techniques. A review of techniques was already given in earlier articles [106,107].

First one has to recognise surface features using various microscopy techniques. Detailed surface feature of PFC (erosion and deposition areas with rough or flaking co-deposits) and dust particles have presented on many occasions, e.g. Refs. [108–111]. In Fig. 25 there are a few examples of tiles with beryllium, tungsten and carbon. Progress in the examination of near-surface structure of PFC surfaces and dust particles is connected with the application of focused ion beam (FIB) technique combined with ultra-high resolution microscopy, especially scanning transmission electron microscopy (STEM) [111–114].

Efficient analysis methods must be sensitive and selective to determine the content and distribution (lateral and in-depth) of hydrogen isotopes and several light and heavier elements listed in Section 4.1. High speed of analysis is also important when surveying (i.e. probing hundreds of points) over large areas of PFC. These criteria are met by ion beam analysis methods, especially accelerator-based techniques [115,116]: Rutherford backscattering spectroscopy, a large family of nuclear reaction analysis, particle-induced X-ray emission (PIXE) and elastic recoil detection analysis (ERDA). Conditions for practical accelerator-based IBA of reactor materials have been compiled in Table 1 of Ref. [106]. That table, however, should be treated only as a certain indication, not as an ultimate recommendation. As already mentioned, there is a steady progress, for instance in fuel retention analysis with high energy  $^3\text{He}$  [117], development of detectors [118], more frequent use of micro-beam and application of accelerator mass spectrometry (AMS) and time-of-flight high-energy elastic recoil detection (ToF-HIERDA).

Two groups of above mentioned IBA methods based on micro-beam and heavy ion beams (e.g. Si, Cl, I) have distinctly improved insight into the morphology of surfaces. Micro-beam

allowed identification of topography-related fine features decisive for fuel retention: accumulation in small cavities acting as local shadowed areas [119–121]. ToF-HIERDA, though its use is limited to studies of smooth surfaces, has allowed development of tracer techniques based on rare low-Z isotopes (e.g.  $^{15}\text{N}$  and  $^{18}\text{O}$ ) [58–60,73–75,122,123].

## 5. Concluding remarks

The overview provided in this paper shows that the broad research program on plasma-wall interactions and material studies was possible due to the combination of research tools. This includes the development and application of versatile probe transfer systems and great flexibility in their operation. The latter means also capabilities of performing extreme power-loading on tested components (sacrificial experiments to determine material operational limits) and the use of non-standard or even hazardous compounds (diborane, silane, hexafluorides) for the elaboration of wall conditioning techniques and in material migration studies. Results have contributed to progressing fusion reactor technology. The most prominent examples are: (i) comparative studies of carbon and heavy metals comprising tests of high-Z metals and composite materials; (ii) above mentioned development of wall conditioning including ion cyclotron-based method; (iii) significant contribution to the development of erosion–deposition diagnostics, i.e. wall probes and tracer techniques.

A comprehensive and consistent program on high-Z metal testing which started in 1992 has been crucial for the reactor wall technology. First it allowed for the comparison of Mo and W pointing to the prevalence of tungsten as a candidate PFM. Activities at TEXTOR followed by a large-scale test of tungsten under divertor conditions in AUG [124,125] and tests in high-heat flux devices [126,127] contributed to the

prediction of material lifetime and fuel inventory in the presence of different wall materials [128]. This, in turn, led to key decisions on the implementation of a full metal wall in JET [129–133]. The reduced fuel inventory JET-ILW in comparison to operations with carbon wall (JET-C) [132–134] has been fundamental for the decision to use a tungsten divertor in ITER from the beginning of reactor operation [135].

The program on testing of composite materials revealed issues with their durability under tokamak operation. This certainly allowed for elimination of at least several materials from the list of PFC candidates. A positive aspect is related to the determination of operational limits with W-coated carbon substrates. That knowledge was eventually beneficial in the R&D process of coated tiles for several tokamaks.

An experience (in TEXTOR and in other machines) with a variety of wall probes, marker tiles, related tools and their implementation techniques has led to the identification of drawbacks and advantages of different designs. A need for such tools has been recognised at ITER, where the application of removable samples with marker coatings was considered and probes were being designed [136].

In this overview we have summarised tools used in PWI studies at TEXTOR, analysis techniques and work procedures. We give a set of references where detailed information can be found. Eventually, two elements are crucial: understanding of physics basis of techniques and laboratory practise including also errors in the operation, i.e. understanding of advantages and limitations of respective methods and procedures in material research in extreme environment. It is a *conditio sine qua non* in a process of designing and selecting a proper set of tools or techniques to solve a given problem.

## Acknowledgements

We express our deep gratitude for all crucial contributions to the program made by Dr. Birger Emmoth (1945–2009) from the Royal Institute of Technology in Stockholm, Sweden. Dr. Emmoth took part in the design and construction of the collector probe system and then for many years he was a leader of the experimental program on measurements of particle fluxes in the scrape-off-layer plasma in the TEXTOR tokamak.

## References

- [1] TEXTOR special issue, Fusion Sci. Technol. 47 (2005).
- [2] G.F. Federici, C.H. Skinner, J.N. Brooks, J.P. Coad, C. Grisolia, et al., Plasma – material interactions in current tokamaks and their implications for next step fusion devices, Nucl. Fusion 41 (2001) 1967.
- [3] V. Philipps, T. Tanabe, Y. Ueda, A. Pospieszczyk, M.Z. Tokar, et al., Molybdenum test limiter experiments in TEXTOR, Nucl. Fusion 34 (1994) 1417.
- [4] V. Philipps, A. Pospieszczyk, A. Huber, A. Kirschner, J. Rapp, et al., Experiments with tungsten limiters in TEXTOR-94, J. Nucl. Mater. 258–263 (1998) 858.
- [5] G. Sergienko, B. Bazylev, T. Hirai, A. Huber, A. Kreter, et al., Experience with bulk tungsten test limiters under high heat loads: melting and melt layer propagation, Phys. Scr. T128 (2007) 81.
- [6] A. Huber, V. Philipps, A. Pospieszczyk, M. Wada, M. Lehnen, et al., Comparison of impurity production, recycling and power deposition on carbon and tungsten limiters in TEXTOR-94, J. Nucl. Mater. 290–293 (2001) 276.
- [7] V. Philipps, R. Neu, J. Rapp, U. Samm, M. Tokar, et al., Comparison of tokamak behaviour with tungsten and low-Z plasma facing materials, Plasma Phys. Control. Fusion 42 (2000) B283.
- [8] J. Winter, Carbonization in tokamaks, J. Nucl. Mater. 145–147 (1987) 131.
- [9] J. Winter, H.G. Esser, L. Könen, V. Philipps, H. Reimer, et al., Boronization in TEXTOR, J. Nucl. Mater. 162–163 (1989) 713.
- [10] J. Winter, H.G. Esser, G.L. Jackson, L. Könen, A. Messiaen, et al., Improved plasma performance in TEXTOR with silicon coated surfaces, Phys. Rev. Lett. 71 (1993) 149.
- [11] K.H. Finken, T. Eich, The dynamic ergodic divertor (DED) for TEXTOR-94 tokamak, Contrib. Plasma Phys. 40 (2000) 57.
- [12] M. Lehnen, S.S. Abdullaev, G. Arnoux, S.A. Bozhenkov, M.W. Jakubowski, et al., Runaway generation during disruptions in JET and TEXTOR, J. Nucl. Mater. 390–391 (2009) 740.
- [13] A. Kirschner, V. Philipps, J. Winter, U. Kögler, Simulation of the plasma-wall interaction in a tokamak with the Monte Carlo code ERO-TEXTOR, Nucl. Fusion 40 (2000) 989.
- [14] S. Brezinsek, G. Sergienko, A. Pospieszczyk, Ph. Mertens, U. Samm, et al., Characterization of the deuterium recycling flux in front of a graphite surface in the TEXTOR tokamak, Plasma Phys. Control. Fusion 47 (2005) 615.
- [15] H.E. Säterblom, M. Braun, B. Emmoth, J. Winter, J. Hilke, et al., A Computer-controlled particle collection and surface analysis system for tokamak scrape-off layer analysis, Nucl. Instr. Methods. A240 (1985) 151.
- [16] B. Schweer, P. Wienhold, M. Rubel, B. Emmoth, R. Zagórski, et al., Fast reciprocating probe system for plasma edge characterization: construction and applications, in: Proc. 2nd German – Polish Conf. On Plasma Diagnostics, Greifswald, Germany, 2002.
- [17] D. Nicolai, V. Borsuk, P. Drews, O. Grulke, K.P. Hollfeld, et al., A Multi-Purpose Manipulator system for W7-X as user facility for plasma edge investigation, in: 29th Symp. On Fusion Technology, P2.073, Prague, Czech Republic, 2016.
- [18] T. Tanabe, V. Philipps, Y. Ueda, B. Unterberg, A. Pospieszczyk, et al., High Z limiter test in TEXTOR: impurity fluxes, thermal response and post-mortem analysis of a Mo limiter head“, J. Nucl. Mater. 212–215 (1994) 1370.
- [19] Y. Ueda, T. Tanabe, V. Philipps, L. Koenen, A. Pospieszczyk, et al., Effects of impurities released from high Z test limiter on plasma performance in TEXTOR, J. Nucl. Mater. 220–222 (1995) 240.
- [20] T. Tanabe, V. Philipps, Y. Ueda, B. Unterberg, A. Pospieszczyk, et al., High Z limiter test in TEXTOR, thermal response and post-mortem analysis, Fusion Eng. Des. 28 (1995) 13.
- [21] M. Rubel, V. Philipps, U. Kögler, T. Tanabe, D. Larsson, et al., Impact of molybdenum and tungsten limiters on impurity fluxes in the scrape-off layer plasma of TEXTOR, J. Nucl. Mater. 249 (1997) 116.
- [22] J. Rapp, M.Z. Tokar, L. Könen, H.R. Koslowski, G. Bertschinger, et al., Transport studies of high-Z elements in neon edge radiation cooled discharges in TEXTOR-94, Plasma Phys. Control. Fusion 39 (1997) 1615.
- [23] M. Wada, V. Philipps, A. Pospieszczyk, B. Unterberg, B. Schweer, et al., Impurity release from high-Z test limiters immersed in TEXTOR-94 edge plasmas, J. Nucl. Mater. 241–243 (1997) 799.
- [24] T. Tanabe, V. Philipps, K. Nakamura, M. Fujine, Y. Ueda, et al., Examination of material performance of W exposed to high heat load, J. Nucl. Mater. 241–243 (1997) 1164.
- [25] M. Wada, T. Tanabe, V. Philipps, B. Unterberg, A. Pospieszczyk, et al., High heat flux exposure experiments of a tungsten test limiter at TEXTOR-94, J. Nucl. Mater. 258–263 (1998) 853.
- [26] M. Rubel, V. Philipps, A. Huber, T. Tanabe, Formation of carbon containing layers on tungsten test limiters, Phys. Scr. T81 (1999) 61.
- [27] T. Tanabe, T. Ohgob, M. Wadac, M. Rubeld, V. Philipps, et al., Material mixing on W/C twin limiter in TEXTOR-94, Fusion Eng. Des. 49 & 50 (2000) 355.

- [28] T. Tanabe, M. Wada, T. Ohgo, V. Philipps, M. Rubel, et al., Application of tungsten for plasma limiters in TEXTOR, *J. Nucl. Mater.* 283–287 (2000) 1128.
- [29] M. Rubel, T. Tanabe, V. Philipps, B. Emmoth, A. Kirschner, et al., Graphite-tungsten twin limiters in studies of material mixing on high heat flux components, *J. Nucl. Mater.* 283–287 (2000) 1089.
- [30] M. Wada, T. Ohgo, A. Pospieszczyk, A. Huber, G. Sergienko, et al., Local emission and core concentration of tungsten in TEXTOR-94 plasmas operated with tungsten test limiter and poloidal limiters, *J. Nucl. Mater.* 290–293 (2001) 768.
- [31] K. Ohya, R. Kawakami, T. Tanabe, M. Wada, T. Ohgo, et al., Simulation study of carbon and tungsten deposition on W/C twin test limiter, *J. Nucl. Mater.* 283–287 (2000) 1182.
- [32] K. Ohya, R. Kawakami, T. Tanabe, M. Wada, T. Ohgo, et al., Simulation calculations on of mutual contamination between tungsten and carbon and its impact on plasma surface interactions, *J. Nucl. Mater.* 290–293 (2001) 303.
- [33] K. Ohya, J. Kawata, T. Tanabe, M. Wada, Y. Ueda, et al., Ion reflection and sputtering at tungsten surface exposed to edge plasmas in TEXTOR, *J. Nucl. Mater.* 258–263 (1998) 1055.
- [34] K. Ohya, J. Kawata, T. Tanabe, M. Wada, T. Ohgo, et al., Particle emission from a tungsten test limiter in TEXTOR-94: a comparison between experimental and Monte Carlo simulated results, *J. Nucl. Mater.* 266–269 (1999) 629.
- [35] K. Ohya, T. Tanabe, M. Wada, T. Ohgo, V. Philipps, et al., Simulation and experimental studies of impurity release from tungsten exposed to edge plasmas in TEXTOR, *Nucl. Instr. Methods B153* (1999) 354.
- [36] K. Ohya, T. Hirai, T. Tanabe, M. Wada, T. Ohgo, et al., Simulation of hydrogen and hydrocarbon release from W-Ta and W-C twin test limiters in TEXTOR edge plasmas, *J. Nucl. Mater.* 313–316 (2003) 571.
- [37] M. Rubel, V. Philipps, A. Pospieszczyk, T. Tanabe, S. Kötterl, An overview of fuel inventory in tungsten and composite limiters, *J. Nucl. Mater.* 307–311 (2002) 111.
- [38] T. Hirai, V. Philipps, T. Tanabe, M. Wada, A. Huber, et al., Hydrogen recycling and microstructures of tantalum and tungsten twin limiters exposed in TEXTOR-94, *J. Nucl. Mater.* 307–311 (2002) 79.
- [39] T. Hirai, M. Rubel, V. Philipps, A. Huber, T. Tanabe, et al., Testing of tungsten and tantalum limiters at the TEXTOR tokamak: material performance and deuterium retention, *Phys. Scr. T103* (2003) 59.
- [40] T. Ohgo, M. Wada, A. Pospieszczyk, W. Biel, K. Kondo, et al., Heat load to a tantalum-tungsten twin-test-limiter and the effect to high-Z core plasma concentration of TEXTOR-94, *J. Nucl. Mater.* 307–311 (2002) 149.
- [41] M. Wada, T. Hirai, T. Ohgo, T. Tanabe, K. Ohya, et al., Inhomogeneous heat loading to high-Z test limiters depending upon the limiter materials, *J. Nucl. Mater.* 313–316 (2003) 292.
- [42] T. Ohgo, M. Wada, K. Ohya, T. Hirai, W. Biel, et al., Effect upon the core plasma radiation due to high power laser injection onto C, W and Ta test limiters in TEXTOR, *J. Nucl. Mater.* 313–316 (2003) 1156.
- [43] T. Hirai, V. Philipps, A. Huber, G. Sergienko, J. Linke, et al., Performance and erosion of a tungsten brush limiter tested at the TEXTOR tokamak, *J. Nucl. Mater.* 313–316 (2003) 69.
- [44] A. Huber, M. Mayer, V. Philipps, A. Pospieszczyk, T. Ohgo, et al., In-situ measurements of trapped hydrogen by laser desorption in TEXTOR-94, *Phys. Scr. T94* (2001) 102.
- [45] A. Huber, V. Philipps, T. Hirai, A. Kirschner, M. Lehnen, et al., Behaviour of silicon doped CFC limiter under high heat load in TEXTOR, *Phys. Scr. T91* (2001) 61.
- [46] P. Mertens, M. Silz, Most recent results from laser-induced fluorescence on TEXTOR 94: atomic silicon, in: *Proc. 7th Symp. Laser-aided Plasma Diag. LAPD-7*, Fukuoka, 1995, p. 150.
- [47] A. Huber, I. Beigman, D. Borodin, Ph. Mertens, V. Philipps, et al., Spectroscopic observation of Si I- and Si II emission lines in the boundary of TEXTOR and comparison with kinetic calculations, *Plasma Phys. Control. Fusion* 45 (2003) 89.
- [48] A. Pospieszczyk, V. Philipps, E. Casarotto, U. Kögler, B. Schweer, et al., Chemical erosion measurements from various carbon based limiters and coatings in TEXTOR, *J. Nucl. Mater.* 241–243 (1997) 883.
- [49] A. Pospieszczyk, B. Schweer, V. Philipps, A. Huber, G. Sergienko, et al., B<sub>4</sub>C-limiter experiments at TEXTOR, *J. Nucl. Mater.* 313–316 (2003) 223.
- [50] M. Laux, W. Schneider, P. Wienhold, B. Jüttner, A. Huber, et al., Arcing at B<sub>4</sub>C-covered limiters exposed to a SOL plasma, *J. Nucl. Mater.* 313–316 (2003) 64.
- [51] S. Kötterl, H. Bolt, H. Greuner, A. Huber, J. Linke, et al., Development of thick B<sub>4</sub>C coatings for the first wall of W7-X, *Phys. Scr. T91* (2001) 117.
- [52] H.G. Esser, J. Winter, V. Philipps, A. Pospieszczyk, J. von Seggern, et al., Protection of limiter surfaces by films locally deposited during TEXTOR discharges, *J. Nucl. Mater.* 220–222 (1995) 457.
- [53] P. Wienhold, H.G. Esser, D. Hildebrandt, A. Kirschner, M. Mayer, et al., Investigation of carbon transport in the scrape-off layer of TEXTOR-94, *J. Nucl. Mater.* 290 – 293 (2001) 362.
- [54] A. Kirschner, A. Huber, V. Philipps, A. Pospieszczyk, P. Wienhold, et al., Modelling of erosion and deposition at limiter surfaces and divertor target plates, *J. Nucl. Mater.* 290 – 293 (2001) 238.
- [55] P. Wienhold, V. Philipps, A. Kirschner, A. Huber, J. von Seggern, et al., Short and long range transport of materials eroded from wall components in fusion devices, *J. Nucl. Mater.* 313–316 (2003) 313.
- [56] M. Rubel, P. Wienhold, D. Hildebrandt, Ion beam analysis methods in studies of plasma facing materials in controlled fusion devices, *Vacuum* 70 (2003) 423.
- [57] V. Philipps, A. Pospieszczyk, H.G. Esser, U. Kögler, G. Mank, et al., Impurity release and deposition processes close to limiter surfaces in TEXTOR, *J. Nucl. Mater.* 241–243 (1997) 105.
- [58] M. Rubel, J. Coenen, D. Ivanova, S. Möller, P. Petersson, et al., Tungsten migration studies by controlled injection of volatile compounds, *J. Nucl. Mater.* 438 (2013) S170.
- [59] M. Rubel, A. Weckmann, P. Ström, P. Petersson, A. Garcia-Carrasco, et al., Tracer techniques for the assessment of material migration and surface modification of plasma facing components, *J. Nucl. Mater.* 463 (2015) 280.
- [60] A. Weckmann, P. Petersson, M. Rubel, P. Wienhold, S. Brezinsek, et al., Local migration studies of high-Z metals in the TEXTOR tokamak, *Phys. Scr. T167* (2016) 014058.
- [61] A. Pospieszczyk, T. Tanabe, V. Philipps, G. Sergienko, T. Ohgo, et al., Operation of TEXTOR with tungsten poloidal main limiters, *J. Nucl. Mater.* 290–293 (2013) S170.
- [62] G. Sergienko, B. Bazylev, A. Huber, A. Kreter, A. Litnovsky, et al., Erosion of tungsten limiter under high-heat flux in TEXTOR, *J. Nucl. Mater.* 363–365 (2001) 947.
- [63] M.J. Rubel, G. Sergienko, A. Kreter, A. Pospieszczyk, M. Psoda, et al., An overview of fuel retention and morphology in a castellated tungsten limiter, *Fusion Eng. Des.* 83 (2008) 1049.
- [64] T. Hirai, E. Bondarchuk, A.I. Borovkov, Th. Koppitz, J. Linke, et al., Development and testing of a bulk tungsten tile for the JET divertor, *Phys. Scr. T128* (2007) 144.
- [65] M. Psoda, M. Rubel, G. Sergienko, P. Sundelin, A. Pospieszczyk, Material mixing on plasma-facing components: compound formation, *J. Nucl. Mater.* 386–388 (2009) 740.
- [66] A. Litnovsky, V. Philipps, P. Wienhold, A. Kreter, A. Kirschner, et al., Overview of material migration and mixing, fuel retention and cleaning of ITER-like castellated structures in TEXTOR, *J. Nucl. Mater.* 415 (2011) S289.
- [67] D. Matveev, A. Kirschner, A. Litnovsky, M. Komm, D. Borodin, et al., Modelling of impurity deposition in gaps of castellated surfaces with the 3D-GAPS code, *Plasma Phys. Contr. Fusion* 52 (2010) 075007.
- [68] K. Ohya, T. Tanabe, M. Rubel, M. Wada, T. Ohgo, et al., Modelling of erosion and deposition patterns on C–W and W–Ta twin limiters exposed to the TEXTOR edge plasmas, *J. Nucl. Mater.* 329–333 (2004) 732.
- [69] V. Philipps, D. Kogut, H.G. Esser, G. Sergienko, M. Zlobinski, et al., Deposition and qualification of tungsten coatings produced by plasma deposition in WF<sub>6</sub> precursor gas, *Phys. Scr. T145* (2011) 014030.
- [70] A. Kirschner, P. Wienhold, V. Philipps, J.P. Coad, A. Huber, et al., Modelling of carbon transport and re-deposition in fusion devices:



- evidence of enhanced re-erosion of in-situ deposited carbon films, *J. Nucl. Mater.* 328 (2004) 62.
- [71] A. Kirschner, A. Kreter, P. Wienhold, S. Brezinsek, J.W. Coenen, et al., Deposition and re-erosion studies by means of local impurity injection in TEXTOR, *J. Nucl. Mater.* 415 (2011) S239.
- [72] A. Kirschner, P. Wienhold, D. Borodin, C. Björkas, O. Van Hoey, et al., Studies of impurity migration in TEXTOR by local tracer injection, *J. Nucl. Mater.* 438 (2013) S723.
- [73] D. Naujoks, R. Behrisch, Erosion and re-deposition at the vessel walls in fusion devices, *J. Nucl. Mater.* 220–222 (1995) 227.
- [74] M.J. Rubel, J.P. Coad, K. Stenström, P. Wienhold, J. Likonen, et al., Overview of tracer techniques in studies of material erosion, re-deposition and fuel inventory in tokamaks, *J. Nucl. Mater.* 329–333 (2004) 795.
- [75] J.P. Coad, J. Likonen, M. Rubel, E. Vainonen-Ahlgren, D.E. Hole, et al., Overview of material re-deposition and fuel retention studies at JET with the Gas Box divertor, *Nucl. Fusion* 46 (2006) 350.
- [76] S.L. Allen, W.R. Wampler, A.G. McLean, D.G. Whyte, W.P. West, et al.,  $^{13}\text{C}$  transport studies in L-mode divertor plasmas on DIII-D, *J. Nucl. Mater.* 337–339 (2005) 30.
- [77] R. Pugno, K. Krieger, M. Airila, L. Aho-Mantila, A. Kreter, et al., Investigation of local carbon transport in the ASDEX Upgrade divertor using  $^{13}\text{CH}_4$  puffing, *J. Nucl. Mater.* 390–391 (2009) 68.
- [78] P. Petersson, M. Rubel, G. Possnert, S. Brezinsek, B. Pegourie, Nuclear reaction and heavy ion ERD analysis of wall materials from controlled fusion devices: deuterium and nitrogen-15 studies, *Nucl. Instr. Methods B273* (2012) 113.
- [79] P. Petersson, M. Rubel, G. Possnert, S. Brezinsek, A. Kreter, et al., Overview of nitrogen-15 application as a tracer gas for material migration and retention studies in tokamaks, *Phys. Scr.* T159 (2014) 014042.
- [80] P. Petersson, A. Hakola, J. Likonen, M. Mayer, J. Miettunen, et al., Injection of nitrogen-15 tracer into ASDEX-Upgrade: new technique in material migration studies, *J. Nucl. Mater.* 438 (2013) S616.
- [81] D. Ivanova, M. Rubel, V. Philipps, B. Schweer, M. Freisinger, et al., Laser-based and thermal methods for fuel removal and cleaning of plasma-facing components, *J. Nucl. Mater.* 415 (2001) S801.
- [82] P. Wienhold, F. Weschenfelder, J. Winter, Colorimetric measurements of carbon erosion and deposition on extended areas of plasma facing components in TEXTOR, *J. Nucl. Mater.* 220–222 (1995) 452.
- [83] P. Wienhold, F. Weschenfelder, Two-dimensional measurements of thin film erosion and deposition by colorimetry of interference colours and its application in fusion devices, *Vacuum* 47 (1996) 919.
- [84] M.J. Rubel, J.P. Coad, G.F. Neill, C. Walker, P. Wienhold, et al., Erosion and re-deposition on diagnostic mirrors for ITER: first mirror test at JET and TEXTOR, in: *Proc. 30th EPS Conf. On Plasma Physics and Controlled Fusion*, Europhys. Conf. Abstracts 27A, 2003.
- [85] P. Wienhold, A. Litnovsky, V. Philipps, B. Schweer, G. Sergienko, et al., Exposure of metal mirrors in the scrape-off layer of TEXTOR, *J. Nucl. Mater.* 337–339 (2005) 1116.
- [86] A. Litnovsky, P. Wienhold, V. Philipps, A. Romanyuk, O. Schmitz, et al., Diagnostic mirrors for ITER: a material choice and the impact of erosion and deposition on their performance, *J. Nucl. Mater.* 363–365 (2007) 1395.
- [87] D. Larsson, M. Rubel, Ion flux measurements with the improved collector probe system at the TEXTOR-94 tokamak, *Rev. Sci. Instr.* 69 (1998) 2671.
- [88] M. Rubel, F. Waelbroeck, H. Bergsäter, P. Wienhold, B. Emmoth, et al., Oxygen impurity analysis by collector probe measurements in the carbonised TEXTOR tokamak, *J. Nucl. Mater.* 161 (1989) 153.
- [89] B. Emmoth, M. Rubel, P. Wienhold, J. Winter, H. Bergsäter, Metal impurity fluxes in the TEXTOR scrape-off layer measured by collector probes in the presence of ALT-II toroidal belt limiter, *J. Nucl. Mater.* 162–164 (1989) 409.
- [90] P. Wienhold, J. Von Seggern, H.G. Esser, J. Winter, H. Bergsäter, et al., Impurity redeposition in the SOL of TEXTOR after boronization, *J. Nucl. Mater.* 176–177 (1990) 150.
- [91] I. Gudowska, H. Bergsäter, B. Emmoth, P. Wienhold, M. Rubel, Fluxes of boron in the scrape-off plasma of TEXTOR following boronization, *J. Nucl. Mater.* 176–177 (1990) 363.
- [92] P. Wienhold, J. Von Seggern, Oxygen gettering on graphite in the SOL of TEXTOR after wall conditioning with boron, *Vacuum* 43 (1992) 745.
- [93] M. Rubel, P. Wienhold, N. Almqvist, B. Emmoth, H.G. Esser, et al., Silicon fluxes in the scrape-off layer plasma during silicon-assisted operation of TEXTOR, *J. Nucl. Mater.* 220–222 (1995) 536.
- [94] M. Rubel, H. Bergsäter, B. Emmoth, P. Wienhold, F. Waelbroeck, et al., Deuterium and impurity fluxes in the TEXTOR scrape-off layer measured at different limiter configurations, *Phys. Scr.* 43 (1991) 508.
- [95] M. Rubel, V. Philipps, U. Kögler, T. Tanabe, D. Larsson, et al., Impact on molybdenum and tungsten test limiters on ion fluxes in the plasma edge of TEXTOR, *J. Nucl. Mater.* 249 (1997) 116.
- [96] M. Rack, Y. Liang, H. Jaegers, J. Aßmann, G. Satheeswaran, et al., A rotating directional probe for the measurements of fast ion losses and plasma rotation at Tokamak Experiment for Technology Oriented Research, *Rev. Sci. Instrum.* 84 (2013) 083501.
- [97] Y. Yang, Y. Liang, Y. Sun, T. Zhang, J. Pearson, et al., Experimental observations of plasma edge magnetic field response to resonant magnetic perturbation on the TEXTOR tokamak, *Nucl. Fusion* 52 (2012) 074014.
- [98] Y. Xu, C. Hidalgo, I. Shesterikov, M. Berte, P. Dumortier, et al., Role of symmetry-breaking induced by  $E_r \times B$  shear flows on developing residual stresses and intrinsic rotation in the TEXTOR tokamak, *Nucl. Fusion* 53 (2013) 072001.
- [99] K. Wongrach, K.H. Finken, S.S. Abdullaev, O. Willi, L. Zeng, et al., Runaway electron studies in TEXTOR, *Nucl. Fusion* 55 (2015) 053008.
- [100] B. Emmoth, A. Kreter, A. Hallén, M. Jakubowski, M. Lehnen, et al., In-situ measurements of carbon and deuterium deposition using the fast reciprocating probe in TEXTOR, *J. Nucl. Mater.* 390–391 (2009) 179.
- [101] N. Almqvist, M. Rubel, S. Fredriksson, B. Emmoth, P. Wienhold, et al., AFM and STM characterization of surfaces exposed to high flux deuterium plasma, *J. Nucl. Mater.* 220–222 (1995) 917.
- [102] N. Almqvist, M. Rubel, P. Wienhold, S. Fredriksson, Roughness determination of plasma-modified surface layers with atomic force microscopy, *Thin Solid Films* 270 (1995) 426.
- [103] S. Muto, T. Tanabe, A. Hirota, M. Rubel, V. Philipps, et al., TEM and EELS characterization of carbon dust and co-deposited layers from the TEXTOR tokamak, *J. Nucl. Mater.* 307–311 (2002) 1289.
- [104] M. Rubel, J. von Seggern, P. Karduck, V. Philipps, A. Vevecka-Priftaj, et al., Analysis and oxidation of thick deposits on TEXTOR plasma-facing components, *J. Nucl. Mater.* 196–199 (1999) 1185.
- [105] M. Rubel, G. De Temmerman, G. Sergienko, P. Sundelin, B. Emmoth, et al., Fuel removal from plasma-facing components by oxidation-based techniques. An overview of surface conditions after oxidation, *J. Nucl. Mater.* 363–365 (2007) 877.
- [106] M. Rubel, Analysis of plasma-facing materials: material migration and fuel retention, *Phys. Scr.* T123 (2006) 55.
- [107] M. Rubel, J.P. Coad, J. Likonen, V. Philipps, Analysis of fuel retention in plasma-facing components from controlled fusion devices, *Nucl. Instr. Methods B267* (2009) 711.
- [108] M. Rubel, E. Fortuna, A. Kreter, E. Wessel, V. Philipps, et al., Overview of comprehensive characterization of erosion zones on plasma facing components, *Fusion Eng. Des.* 81 (2006) 211.
- [109] M. Rubel, M. Cecconello, Ja Malmberg, G. Sergienko, W. Biel, et al., Dust particles in controlled fusion devices: morphology, observations in the plasma and influence on the plasma performance, *Nucl. Fusion* 41 (2001) 1087.
- [110] E. Fortuna, M. Rubel, M. Psoda, M. Andrzejczuk, K.J. Kurzydowski, et al., Plasma induced damage of tungsten coatings on graphite limiters, *Phys. Scr.* T128 (2007) 162.
- [111] E. Fortunazalesna, A. Weckmann, J. Grzonka, M. Rubel, H.G. Esser, et al., Dust survey following the final shutdown of TEXTOR: metal particles and fuel retention, *Phys. Scr.* T167 (2016) 014059.
- [112] J. Grzonka, L. Ciupinski, J. Smalckoziorowska, O.V. Ogorodnikova, M. Mayer, et al., Electron microscopy observation of radiation damage

- in irradiated and annealed tungsten, Nucl. Instr. Methods B340 (2014) 27.
- [113] A. Garcíacarrasco, P. Petersson, A. Hallen, J. Grzonka, M.R. Gilbert, et al., Impact of helium implantation and ion-induced damage on reflectivity of molybdenum mirrors, Nucl. Instr. Methods B382 (2016) 91.
- [114] A. Baronwiechec, E. Fortunazalešna, J. Grzonka, M. Rubel, A. Widdowson, et al., First dust study in JET with the ITER-like wall: sampling, analysis and classification, Nucl. Fusion 55 (2015) 113033.
- [115] J.W. Mayer, E. Rimini, Ion Beam Handbook for Material Analysis, Academic Press, New York, 1977.
- [116] J.R. Tesmer, M. Nastasi (Eds.), Handbook of Modern Ion Beam Analysis, Materials Research Society, Pittsburg, USA, 1995.
- [117] M. Mayer, E. Gauthier, K. Sugiyama, U. Von Toussaint, Quantitative depth profiling of deuterium up to very large depths, Nucl. Instr. Methods B267 (2009) 506.
- [118] P. Strom, P. Petersson, M. Rubel, G. Possnert, A combined segmented anode gas ionization chamber and time-of-flight detector for heavy ion elastic recoil detection analysis, Rev. Sci. Instrum. 87 (2016) 103303.
- [119] P. Petersson, A. Kreter, G. Possnert, M. Rubel, Nuclear micro-beam analysis of deuterium distribution in carbon fibre composites for controlled fusion devices, Nucl. Instr. Methods B268 (2010) 1833.
- [120] P. Petersson, M. Rubel, G. Possnert, B. Pegourie, Micro-distribution of fuel and metal in carbon-based plasma-facing materials, Phys. Scr. T145 (2012) 014014.
- [121] H. Bergsaker, I. Bykov, P. Petersson, G. Possnert, J. Likonen, et al., Microstructure and inhomogeneous fuel trapping at divertor surfaces in the JET tokamak, Nucl. Instr. Methods B332 (2014) 266.
- [122] A.G. Carrasco, S. Moller, P. Petersson, D. Ivanova, A. Kreter, et al., Impact of ion cyclotron wall conditioning on fuel removal from plasma-facing components at TEXTOR, Phys. Scr. T159 (2014) 014017.
- [123] A.G. Carrasco, T. Wauters, P. Petersson, A. Drenik, M. Rubel, et al., Nitrogen removal from plasma-facing components by ion cyclotron wall conditioning in TEXTOR, J. Nucl. Mater. 463 (2015) 688.
- [124] R. Neu, V. Bobkov, R. Dux, J. Fuchs, O. Gruber, et al., Ten years of W program in ASDEX upgrade-challenges and conclusions, Phys. Scr. T138 (2009) 014038.
- [125] R. Neu, A. Kallenbach, M. Balden, V. Bobkov, J.W. Coenen, et al., Overview on plasma operation with a full tungsten wall in ASDEX Upgrade, J. Nucl. Mater. 438 (2013) S34.
- [126] J. Linke, F. Escourbiac, I.V. Mazul, R.E. Nygren, M. Rodig, et al., High heat flux testing of plasma facing materials and components – status and perspectives for ITER related activities, J. Nucl. Mater. 367–370 (2007) 1422.
- [127] J. Linke, Plasma facing materials and components for future fusion devices—development, characterization and performance under fusion specific loading conditions, Phys. Scr. T123 (2006) 45.
- [128] J. Roth, E. Tsitrone, A. Loarte, T. Loarer, G.F. Counsell, et al., Recent analysis of key plasma wall interactions issues for ITER, J. Nucl. Mater. 390–391 (2009) 1.
- [129] G.F. Matthews, P. Edwards, T. Hirai, M. Kear, A. Lioure, et al., Overview of the ITER-like wall project, Phys. Scr. T128 (2007) 137.
- [130] G.F. Matthews, P. Edwards, H. Greuner, A. Loving, H. Maier, et al., Current status of the JET ITER-like wall project, Phys. Scr. T138 (2009) 014030.
- [131] G.F. Matthews, M. Beurskens, S. Brezinsek, M. Groth, E. Joffrin, et al., JET ITER-Like wall – overview and experimental program, Phys. Scr. T145 (2012) 014001.
- [132] G.F. Matthews, JET-EFDA Contributors, ASDEX-Upgrade Team, Plasma operation with an all metal first-wall: comparison of an ITER-like wall with a carbon wall in JET, J. Nucl. Mater. 438 (2013) S2.
- [133] S. Brezinsek, A. Widdowson, M. Mayer, V. Philipps, P. Baronwiechec, et al., Beryllium migration in JET ITER-like wall plasmas, Nucl. Fusion 55 (2015) 063021.
- [134] T. Loarer, S. Brezinsek, V. Philipps, J. Bucalossi, D. Douai, et al., Comparison of long term fuel retention in JET between carbon and the ITER-like wall, J. Nucl. Mater. 438 (2013) S108.
- [135] R.A. Pitts, S. Carpentier, F. Escourbiac, T. Hirai, V. Komarov, et al., A Full tungsten divertor for ITER: physics issues and design status, J. Nucl. Mater. 438 (2013) S48.
- [136] Ph. Mertens, O. Neubauer, V. Philipps, S. Ciattaglia, A. Huber, et al., Removable samples for ITER: feasibility and conceptual study, Phys. Scr. T159 (2014) 014004.