

# High Power Laser Science and Engineering

<http://journals.cambridge.org/HPL>

Additional services for *High Power Laser Science and Engineering*:

Email alerts: [Click here](#)

Subscriptions: [Click here](#)

Commercial reprints: [Click here](#)

Terms of use : [Click here](#)



---

## Design and current progress of the Apollon 10 PW project

J.P. Zou, C. Le Blanc, D.N. Papadopoulos, G. Chériaux, P. Georges, G. Mennerat, F. Druon, L. Lecherbourg, A. Pellegrina, P. Ramirez, F. Giamb Bruno, A. Fréneaux, F. Leconte, D. Badarau, J.M. Boudenne, D. Fournet, T. Valloton, J.L. Paillard, J.L. Veray, M. Pina, P. Monot, J.P. Chambaret, P. Martin, F. Mathieu, P. Audebert and F. Amiranoff

High Power Laser Science and Engineering / Volume 3 / 2015 / e2

DOI: 10.1017/hpl.2014.41, Published online: 23 January 2015

**Link to this article:** [http://journals.cambridge.org/abstract\\_S2095471914000413](http://journals.cambridge.org/abstract_S2095471914000413)

### How to cite this article:

J.P. Zou, C. Le Blanc, D.N. Papadopoulos, G. Chériaux, P. Georges, G. Mennerat, F. Druon, L. Lecherbourg, A. Pellegrina, P. Ramirez, F. Giamb Bruno, A. Fréneaux, F. Leconte, D. Badarau, J.M. Boudenne, D. Fournet, T. Valloton, J.L. Paillard, J.L. Veray, M. Pina, P. Monot, J.P. Chambaret, P. Martin, F. Mathieu, P. Audebert and F. Amiranoff (2015). Design and current progress of the Apollon 10 PW project. High Power Laser Science and Engineering, 3, e2 doi:10.1017/hpl.2014.41

**This article belongs to a collection:** [Special Issue on High Energy Density Physics and High Power Laser](#)

**Request Permissions :** [Click here](#)

# Design and current progress of the Apollon 10 PW project

J.P. Zou<sup>1</sup>, C. Le Blanc<sup>1</sup>, D.N. Papadopoulos<sup>1</sup>, G. Chériaux<sup>2</sup>, P. Georges<sup>3</sup>, G. Mennerat<sup>4</sup>, F. Druon<sup>3</sup>, L. Lecherbourg<sup>1</sup>, A. Pellegrina<sup>1,3</sup>, P. Ramirez<sup>1,3</sup>, F. Giambruno<sup>1,2</sup>, A. Fréneau<sup>1,2</sup>, F. Leconte<sup>1,2</sup>, D. Badarau<sup>1</sup>, J.M. Boudenne<sup>1</sup>, D. Fournet<sup>1</sup>, T. Valloton<sup>1</sup>, J.L. Paillard<sup>1</sup>, J.L. Veray<sup>1</sup>, M. Pina<sup>1</sup>, P. Monot<sup>4</sup>, J.P. Chambaret<sup>4</sup>, P. Martin<sup>4</sup>, F. Mathieu<sup>1</sup>, P. Audebert<sup>1</sup>, and F. Amiranoff<sup>1</sup>

<sup>1</sup>Laboratoire pour l'Utilisation des Lasers Intenses, CNRS, Ecole Polytechnique, Palaiseau, France

<sup>2</sup>Laboratoire d'Optique Appliquée, ENSTA ParisTech, CNRS, Palaiseau, France

<sup>3</sup>Laboratoire Charles Fabry, UMR 8501, Institut d'Optique, CNRS, Université Paris Sud, Palaiseau, France

<sup>4</sup>CEA, Iramis, SPAM, Saclay, France

(Received 9 July 2014; revised 26 August 2014; accepted 22 October 2014)

## Abstract

The objective of the Apollon project is the generation of 10 PW peak power pulses of 15 fs at 1 shot/minute. In this paper the Apollon facility design, the technological challenges and the current progress of the project will be presented.

**Keywords:** titanium lasers; PW class facilities

## 1. Introduction

The main goal of the Apollon project is to provide to users 10 PW peak power pulses at a repetition rate of 1 shot/minute. To reach this extreme peak power level, Apollon will produce extremely short pulses of 15 fs and a corresponding moderate energy of 150 J after compression. This is in fact the principal difference of Apollon when compared with other multi-PW projects internationally (ELI-NP, Vulcan 10 PW, SIOM 10 PW project etc.) where pulse duration in the range of 25–40 fs is targeted.

The main 10 PW beam, combined with three secondary beams (a 1 PW beam, a 10 TW probe and the uncompressed high energy beam), will generate intensity on target surpassing the barrier of  $2 \times 10^{22} \text{ W cm}^{-2}$ , capable of producing ultra-intense and ultra-short sources of particles (electrons, protons...), and coherent and highly energetic X rays. The design and the construction of the Apollon sub-laser systems have been performed in the framework of a French multi-laboratory research consortium. Apollon will be integrated as an upcoming user facility at the end of 2014 at l'Orme des Merisiers, Saclay, France.

## 2. Apollon architecture strategy

The Apollon architecture has been defined taking into account the current advances in research and development of the laser technology, laser components and laser materials for ultra-short, ultra-intense laser systems. To produce 10 PW pulses, it is important to determine the output energy level and the ultra-short pulse duration.

Apollon will produce a relatively moderate output energy of 150 J, limited by the size and the damage threshold of the broadband gratings used for pulse compression. In addition, for higher output energy, even larger gain media and more significant pump energy would be required. As a consequence, the transverse lasing risk in such media would be more accentuated and the shot repetition rate compromised.

Apollon will produce high-contrast ultra-short pulses of 15 fs, based on excellent spectral bandwidth management and spectral phase minimization all along the chain. In fact, a large spectral bandwidth of about 200 nm and active spectral phase compensation are needed to support high energy 15 fs pulse generation. However, the main aspects responsible for the pulse duration enlargement and contrast degradation are as follows: the spectral gain narrowing and deformation during energy amplification; the time delay

Correspondence to: J.P. Zou, Laboratoire pour l'Utilisation des Lasers Intenses, CNRS, Ecole Polytechnique, Palaiseau, France.  
Email: [ji-ping.zou@polytechnique.fr](mailto:ji-ping.zou@polytechnique.fr)

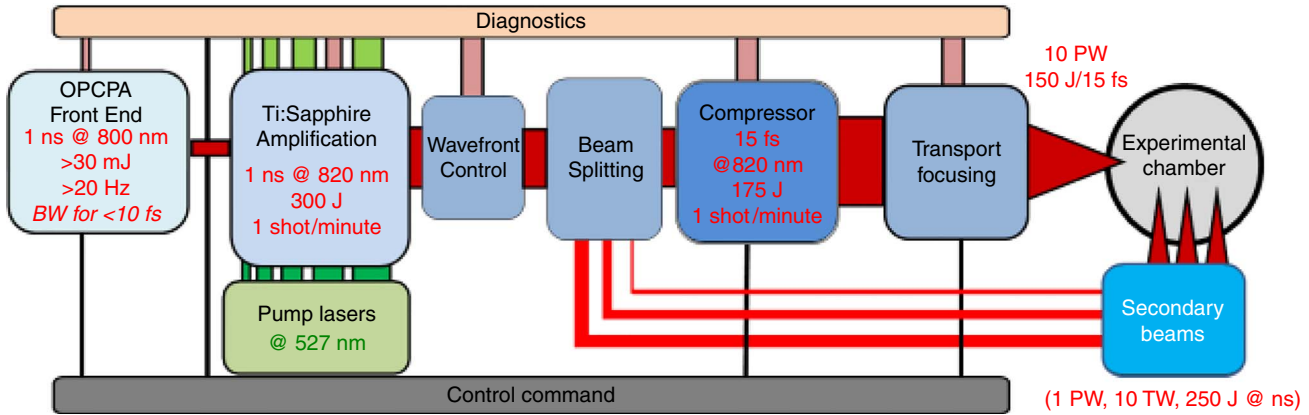

Figure 1. Global schematic of the Apollon 10 PW laser installation.

induced by the longitudinal chromatism generated in spatial filters; the spectral phase induced by material dispersion; and the broadband reflectance limitation and the group delay dispersion (GDD) of the beam-steering mirrors in the chain. For such a laser system, relying on a very broad spectrum, the spatio-temporal coupled effects are of particular importance to study. In the Apollon sub-system design, all of the factors explained in this section will be taken into consideration.

### 3. Sub-system design

To meet the complete set of requirements, the Apollon design is based on a hybrid OPCA-Ti:sapphire architecture. A simplified schematic of the Apollon laser is shown in Figure 1. The design of the Apollon sub-systems including the front-end, the power amplification section (PAS) and the 10 PW compression will be described in the three following sections.

#### 3.1. Apollon front-end

The OPCA-based Apollon front-end employs state of the art technology to generate high quality and high temporal contrast pulses with a spectrum supporting sub-10 fs pulse duration. A non-collinear OPCA architecture using BBO crystals has been chosen to allow broad-bandwidth amplification. A particular feature of our design is that the 2-grating aberration-free Offner stretcher is integrated in the front-end between two OPCA stages. The first OPCA stage operating in the picosecond regime provides high gain ( $1000\times$ ) and temporal contrast enhancement, while the second OPCA stage operates in a low gain ( $50\text{--}100\times$ ) but energetic nanosecond regime.

Both the injection pulses at 800 nm and the pump pulses (SHG of 1030 nm) are provided by a broadband Ti:sapphire oscillator (Rainbow, Femtolasers) for optimal temporal synchronization.

The mJ, 25 fs injection pulses (femtopower) are first temporally cleaned and spectrally broadened in a novel double crossed polarized wave (XPW) configuration<sup>[1]</sup>, and then stretched in a bulk stretcher (BK7). The spectral phase is actively controlled by a double passed Dazzler (Fastlite). After a final spatial filtering stage, about  $2\ \mu\text{J}$ , 6 ps stretched pulses with excellent spatial, temporal and spectral quality and stability are injected into the ps-OPCA stage.

For the OPCA pump lasers, diode pumped Yb-doped crystal technology is used. The pJ level pulses at 1030 nm from the Ti:sapphire oscillator are first temporally stretched and pre-amplified to the mJ level in the nanosecond regime. Amplification then takes place in two parallel chains: (a) the picosecond line based on an Yb:CaF<sub>2</sub> multipass amplifier providing  $>15\ \text{mJ}$  of pump energy at 515 nm after compression and SHG, and (b) the nanosecond line based on an Yb:YAG regenerative amplifier<sup>[2]</sup> followed by an Yb:CaF<sub>2</sub> booster to reach  $>300\ \text{mJ}$  at 515 nm at 20–100 Hz repetition rate<sup>[3]</sup>.

So far we have performed OPCA experiments in the picosecond regime resulting in more than 7 mJ pulses at 100 Hz. Figure 2 shows an OPCA output spectral profile and phase (left) and corresponding compressed pulse of 9.5 fs (right) with a contrast better than  $10^{-12}$ .

#### 3.2. Apollon power amplification

The PAS is based on 5 multipass Ti:sapphire amplifiers to obtain 300 J before compression. Four main points are investigated.

- (1) The spectral evolution management, aiming to optimize spectral profile and width compatible with high-contrast 15 fs pulses: spectral filters are designed to fight against gain narrowing and spectral shifting due to the saturation<sup>[4]</sup>. Two sets of these filters will be set up at the entrance of the PAS

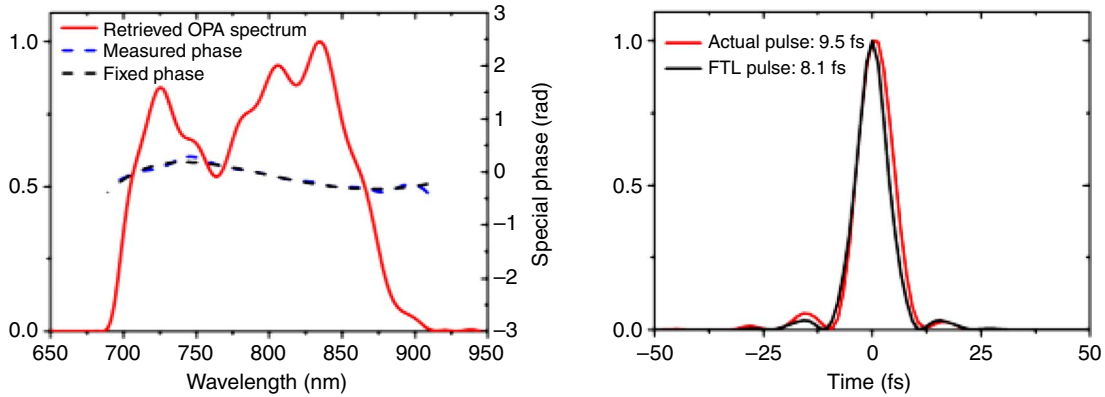

**Figure 2.** Measurement of the compressed ps-OPCPA pulses: spectral profile and phase (left) and pulse intensity (right).

and before the 3rd amplifier to allow optimal energy amplification while preserving  $\sim 70$  nm bandwidth (FWHM) centered at 820 nm. Using another front-end with 50 nm spectral bandwidth, we have demonstrated spectral management with such filters at the 3 J level and compressibility down to 23.5 fs of the amplified pulses.

- (2) The beam quality control including beam energy distribution optimization and beam wavefront correction. This will be achieved by performing image relay through the whole chain using the well studied off-axis parabolic telescopes and an optical adaptive closed-loop. An optimized spatial filtering will also be implemented to minimize the intensity modulations at high spatial frequencies. In this way, the focal spot quality characterized by a Strehl ratio  $>0.5$  should be effectively obtained.
- (3) Transverse lasing suppression: Apollon employs the largest ever grown crystals, reaching 175 mm in diameter (GT Crystal Systems) and pumped areas as large as 150 mm for the last stage. Diameter-to-thickness ratios even greater than 3.5 and high pump energy densities of more than  $1 \text{ J cm}^{-2}$  make the management of parasitic transverse effects a crucial and challenging task. For the suppression of transverse lasing, novel techniques have been explored based on the use of index-matched liquid. The originality of our approach is related to the online, active control of the minimization of the refractive index difference between the crystal and the liquid. Preliminary experimental tests, in excellent accordance with our simulations, have recently provided solid proof of the efficiency of our method.
- (4) High energy pump lasers: a total energy amount of 800 J in the green is required for pumping the last three stages of the PAS. A commercial pump system developed by Continuum & National Energetics will

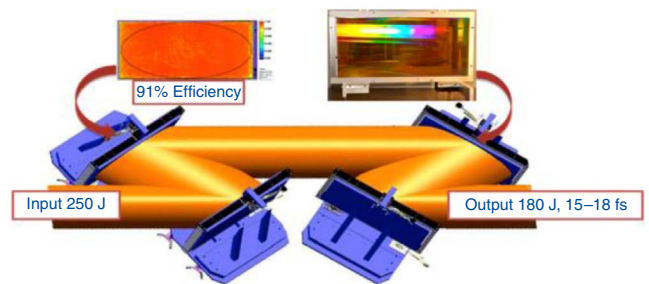

**Figure 3.** Compressor design with four monolithic gratings. Typical efficiency map for a grating.

be used in Apollon. This laser uses flashlamp pumped large Nd-glass multi-slab amplifiers and liquid cooling allowing an operation rate of at least 1 shot/minute. The first module of the pump system, providing 400 J, will be delivered at the end of 2014.

### 3.3. Apollon pulse compression

The main beam line compressor of Apollon is based on a typical four grating unfolded configuration (Figure 3). It has been designed on the basis of three principal considerations. The targeted ultra-short pulse duration after compression corresponds to a very large spectral bandwidth (200 nm full bandwidth at 820 nm) and needs accurate spectral phase management. The damage threshold of the gratings is also an important issue. In fact, to deliver 10 PW pulses to the experiments, energy of 180 J is required at the output of the compressor, corresponding to about 250 J at the input for a compression assuming an efficiency of  $>70\%$ . Existing grating technology, however, limits our choice to gold-coated gratings as the only compatible solution with the required bandwidth of 720–920 nm and a damage threshold in the range of  $200\text{--}300 \text{ mJ cm}^{-2}$ . In our design, the peak fluence on the first grating of  $<110 \text{ mJ cm}^{-2}$  imposes the use of a 400 mm beam size and therefore meter-long gratings.

The Apollon compressor employs gratings of  $910 \times 455 \text{ mm}^2$  manufactured by Laurence Livermore National Laboratory (LLNL). Since January 2012, six of these gratings have been received and fully characterized. The gratings have  $1480 \text{ l mm}^{-1}$  and their diffraction efficiency has been measured to be better than 92% on three wavelengths (780, 800, and 840 nm). The wavefront error of the diffracted beam is lower than  $\lambda/3 \text{ PtV}$  over the whole effective surface. Taking into account the geometrical limitations due to the large beam section, the incident angle has been set at  $56^\circ$ . The spectral phase induced by the material dispersion in the laser chain, as well as the GDD of the mirror coating, has then been minimized based on the design of an unmatched stretcher in the front-end which uses two  $1450 \text{ l mm}^{-1}$  gratings at the incident angle of  $52.4^\circ$ . The compensation of the residual higher order spectral phase by Dazzler will enable us to reach a final duration below 15 fs after pulse compression.

The compressor will be implemented in a large stainless steel vacuum chamber ( $6.2 \times 3 \times 3.1 \text{ m}^3$ ) specified to provide a vacuum level of  $10^{-7} \text{ mbar}$  and cleanliness of ISO6. The large size of the chamber allows entry to the compressor

from a single entrance and handling and alignment of the gratings inside the chamber. Delivery of the chamber is scheduled for September 2014.

### Acknowledgements

The authors gratefully acknowledge financial support from the ILE-APOLLON 07-CPER 017-01 contract.

### References

1. L. P. Ramirez, D. N. Papadopoulos, A. Pellegrina, P. Georges, F. Druon, P. Monot, A. Ricci, A. Jullien, X. Chen, J. P. Rousseau, and R. Lopez-Martens, *Opt. Express* **19**, 93 (2011).
2. J. Tümmler, R. Jung, H. Stiel, P. V. Nickles, and W. Sandner, *Opt. Lett.* **34**, 1378 (2009).
3. D. N. Papadopoulos, F. Friebe, A. Pellegrina, M. Hanna, P. Camy, J.-L. Doualan, R. Moncorge, P. Georges, and F. Druon, *IEEE JSTQE* **21**, 1 (2015).
4. F. Giambruno, C. Radier, G. Rey, and G. Chériaux, *Appl. Opt.* **50**, 2617 (2011).