

Research on the transmission performance of turbo codes in DDO-OFDM system*

TONG Zheng-rong (童峥嵘), HU Gui-bin (胡桂彬)**, CAO Ye (曹晔), and ZHANG Wei-hua (张卫华)

Key Laboratory of Film Electronics and Communication Devices and Key Laboratory of Intelligent Computing and Novel Software Technology, Tianjin University of Technology, Tianjin 300384, China

(Received 11 November 2014)

©Tianjin University of Technology and Springer-Verlag Berlin Heidelberg 2015

A direct detection optical orthogonal frequency division multiplexing (DDO-OFDM) system using turbo codes is built, and the transmission performance comparison between coded system and uncoded system is analyzed. Three decoding algorithms, which are Log-maximum a posteriori (MAP), Max-Log-MAP and threshold Max-Log-MAP, are used in the turbo coded system. By comparing three decoding algorithms, the system using Max-Log-MAP algorithm has the best bit error rate (BER) performance. At the transmission distance of 240 km, the uncoded system with transmission rate of 30 Gbit/s can get the BER performance at the degree of 8.93×10^{-3} with optical signal to noise ratio (OSNR) of 24 dB, while the turbo coded system with transmission rate of 50 Gbit/s can achieve it within OSNR of 20 dB.

Document code: A **Article ID:** 1673-1905(2015)02-0134-3

DOI 10.1007/s11801-015-4210-3

For the transmission system with data rate of 100 Gbit/s or even higher, the signal quality is significantly degraded due to the impact of polarization mode dispersion (PMD) and intra-channel nonlinear effects. Currently, the main approaches to high-speed long-haul optical transmission systems include accurate chromatic dispersion (CD) compensation and PMD compensation^[1], advanced modulation formats and channel coding. After channel coding, the orthogonal frequency division multiplexing (OFDM) system can not only work in higher bit error rate (BER) channel, but also decrease the sensitivity requirement of devices. Meanwhile, the tolerance sensitivity to CD, nonlinear effects and optical signal to noise ratio (OSNR) will be improved. Consequently, the channel coding is very beneficial to high-speed long-dual transmission system.

The performance of turbo code is infinitely close to the Shannon limit. It is believed that turbo code has played an important role in communication systems. Since turbo code was first proposed in 1993^[2], the research of turbo code has become a hot point, which mainly focuses on coding formats, interleaving formats, decoding algorithms, and so on^[3]. Turbo code has been widely used in satellite communication, wireless mobile communication and multimedia communication^[4]. Lee S. H. et al^[5] proposed a turbo code-based error correction scheme in visible light communication systems. Xie Wei et al^[6] built an optical OFDM multimode fiber communication system with turbo codes, convolutional codes

and concatenated codes by Simulink, and proved that turbo codes got a lower BER. Zizheng Cao et al^[7] proposed that the receiver sensitivity would be improved as far as 5 dB by using turbo code and bit interleaver technologies in a 60 GHz OFDM radio-over-fiber (ROF) system.

In this paper, a direct detection optical (DDO) OFDM system using turbo code over single mode fiber is presented, and then three decoding algorithms are employed in this system, respectively. From the simulation software, the performances of the systems using three decoding algorithms are analyzed in three aspects, which are transmission distance, transmission rate and the number of iterations.

Fig.1 shows the block diagram of the DDO-OFDM system. Compared with the uncoded system, two parts of turbo encoder and turbo decoder are employed in the coded system. The input source data are firstly encoded by turbo encoder, and then the serial sequence is converted to parallel sequence (S/P). The data are mapped to complex signal, through inverse fast Fourier transform (IFFT) and adding cyclic prefix (CP) to become base-band OFDM signal. Next, it passes through the digital to analog converter (DAC) and is uploaded to middle frequency to complete the radio frequency (RF) modulation. The RF signal passes through Mach-Zehnder modulator (MZM) to produce optical OFDM signal, and then propagates in optical fiber link. The received signal is transmitted through the optical filter to filter out the

* This work has been supported by the National Natural Science Foundation of China (No.61107052), the Tianjin Natural Science Foundation of China (No.11JCYBJC0010), and the Tianjin Youth Foundation of China (No.13JCQNJC01800).

** E-mail:gui_bin_2009@126.com

noise out of band, the optical signal is transformed to electrical signal by photodetector (PD), then the electrical signal is downloaded to baseband, and after a series of signal processing, the received information bits are delivered to the turbo decoder. In this part, three algorithms of Log-maximum a posteriori (MAP), Max-Log-MAP and threshold Max-Log-MAP^[8,9] are employed to decode the received information.

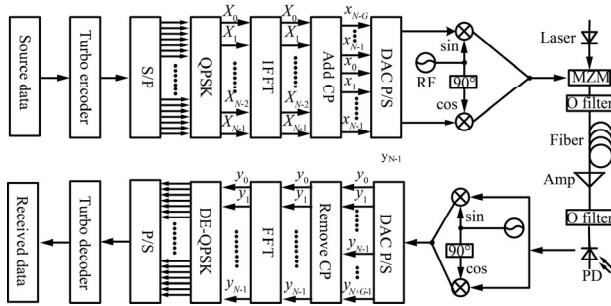

Fig.1 Block diagram of DDO-OFDM system

As a proposed standard for long-haul optical communication^[10], the DDO-OFDM system is combined with multi-carrier modulation technology, digital signal processing (DSP) technology and optical detection technology. The OFDM baseband signal is generated by Matlab, and the optical transmission system is simulated by OptiSystem. In OptiSystem, the signal is up-converted to middle frequency to be uploaded to optical domain for transmission. At the receiver, PD is employed to complete the optical-to-electronic conversion, and then the signal is processed by Matlab to recover the original signal.

Tab.1 gives the parameters assumed in the simulation. Two simulation softwares of Matlab and Optisystem are used in the system.

Tab.1 Parameters assumed in the simulation

Parameter	Value
Sub-carrier	128
Number of OFDM symbols	200
Format of digital mapping	QPSK
Format of code	Turbo code
Code rate	0.5
Bit rate	50 Gbit/s, 30 Gbit/s
Sequence length	65 536
Interleaving format	Random interleaving
Decoding algorithm	Log-MAP, Max-Log-MAP, threshold Max-Log-MAP
Number of FFTs	128
Length of cyclic prefix	32
CD coefficient of fiber	16.75 ps/(nm·km)
Differential group delay	0.2 ps/km
Dark current of PD	10 nA
Gain of optical amplifier	16 dB
Noise figure	3.2 dB
Attenuation coefficient of fiber	0.2 dB/km

From the simulation, the relationship between OSNR and BER is obtained, and the performance of DDO-OFDM system using turbo code is analyzed for different decoding algorithms, different transmission rates, different transmission distances and different iterations.

The simulation parameters are given as follows: the transmission rate is 50 Gbit/s, the transmission distance is 3×80 km, and the interleaving length is 25 597. The BER curves of the systems using three different decoding algorithms are shown in Fig.2. At the OSNR of 24 dB, compared with the uncoded system, the BER performance can be improved from the degree of 10⁻¹ to the degree of 10⁻³ for the turbo coded system using Max-Log-MAP decoding algorithm, and to the degree of 4.38×10⁻³ for the turbo coded system using Log-MAP decoding algorithm. At the OSNR of 27 dB, the BER is 3.91×10⁻⁵ for the turbo coded system using Max-Log-MAP decoding algorithm. The BER performance of the turbo coded system using threshold Max-Log-MAP decoding algorithm is not improved compared with that of the uncoded system.

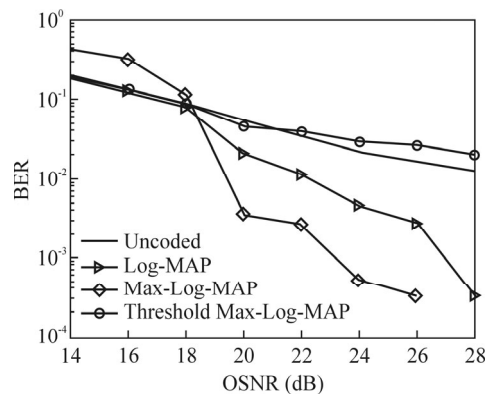

Fig.2 BER performance comparison of DDO-OFDM systems using different decoding algorithms

The BER performances of DDO-OFDM systems with different transmission rates of 30 Gbit/s and 50 Gbit/s are analyzed, and the simulation results are shown in Fig.3. From the simulation results, we can see that at the transmission distance of 240 km, the turbo coded system with Max-Log-MAP decoding algorithm can get the best performance at different rates. Comparing the uncoded system at transmission rate of 30 Gbit/s with the turbo coded system employing Max-Log-MAP decoding algorithm at transmission rate of 50 Gbit/s, we can come to a conclusion that at OSNR of 24 dB, the BER performance can be improved from the degree of 10⁻¹ to 10⁻³, and when OSNR is 26 dB, the BER of uncoded system is 5.88×10⁻³, while that of the turbo coded system is 3.13×10⁻⁴.

With the transmission rate of 50 Gbit/s, the OSNR of 24 dB and the interleaving length of 25 597, the relationship between transmission distance and BER is shown in Fig.4 for the system with the decoding algorithms of Log-MAP and Max-Log-MAP. Fig.4 shows that with the increase of transmission distance, the BER

performance gets worse rapidly. At the BER of 2.73×10^{-3} , compared with uncoded system, the transmission distance of turbo coded system can be increased by 220 km. When the transmission distance is less than 320 km, the BER performance can be greatly improved by turbo coding. If the transmission distance exceeds 320 km, the influence of turbo coding is very little. The system employing Max-Log-MAP algorithm gets better performance than that employing Log-MAP algorithm with transmission distance of 450 km.

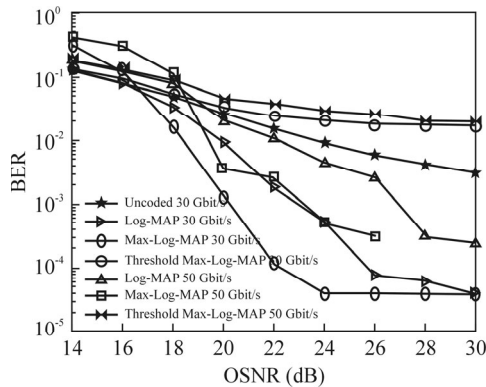

Fig.3 BER performance comparison of DDO-OFDM systems with different transmission rates

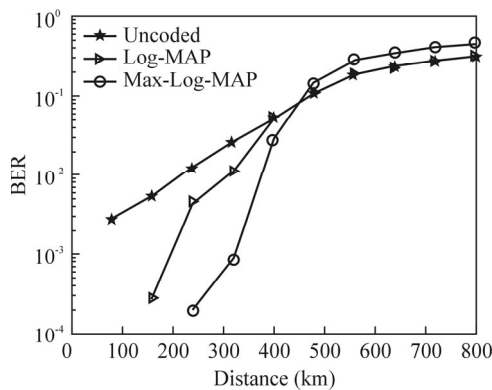

Fig.4 The relationship between BER and transmission distance for uncoded and coded systems

When the transmission rate is 50 Gbit/s, the transmission distance is 240 km, and the interleaving length is 25 597, BER curves of systems with different iterations are shown in Fig.5. From Fig.5, we can see that the BER performance gets better with increasing the number of iterations. When the OSNR is greater than 18 dB, the system employing Log-MAP decoding algorithm with 4 iterations can achieve error-free transmission. The BER performance of system using Max-Log-MAP decoding algorithm with 4 iterations is better than that using Log-MAP decoding algorithm with only one iteration. However, the BER performance of system using threshold Max-Log-MAP decoding algorithm is not improved by increasing the number of iterations.

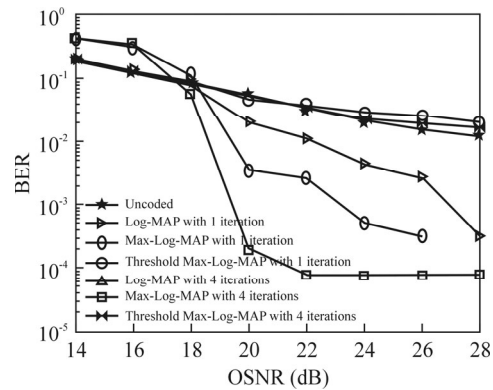

Fig.5 BER performance comparison of turbo coded systems with different iterations

The results show that the turbo coded DDO-OFDM system can avoid the inter symbol interference (ISI) caused by CD and PMD effectively, and the system using Max-Log-MAP decoding algorithm can obtain the best BER performance. When OSNR is 24 dB at 50 Gbit/s with BER of 2.73×10^{-3} , the transmission distance of DDO-OFDM system using turbo code can be increased by 220 km compared with that of the uncoded DDO-OFDM system. At the transmission distance of 240 km, the turbo coded system at transmission rate of 50 Gbit/s can obtain extra 10 dB gain compared with the uncoded system at transmission rate of 30 Gbit/s at the BER of 3.14×10^{-3} .

References

- [1] Zhang Hongbo, Gao Xiang, Zhang Jing, Deng Mingliang and Qiu Kun, Journal of Optoelectronics-Laser **24**, 493 (2013). (in Chinese)
- [2] Berrou C., Glavieux A. and Thitimajshima P., Near Shannon Limit Error-Correcting Coding and Decoding: Turbo-Codes, IEEE International Conference on Communications **2**, 1064 (1993).
- [3] Praba S. J. V. and Vijayalakshmi K., International Journal of Innovative Research and Development **2**, 348 (2013).
- [4] Wu Yucheng, Fu Yiru and Huang Tiancong, Journal of ChongQing University (Natural Science Edition) **9**, 49 (2004). (in Chinese)
- [5] Lee S. H. and Kwon J. K., IEEE Photonics Technology Letters **24**, 1463 (2012).
- [6] Wei X., Guijun H. and Qing D., Optics Communications **281**, 1118 (2008).
- [7] Zizheng Cao, Jianjun Yu, Minmin Xia, Qi Tang, Yang Gao, Wenpei Wang and Lin Chen, Journal of Lightwave Technology **28**, 2423 (2010).
- [8] Wang Z. and Parhi K. K., IEEE Transactions on Communications **51**, 570 (2003).
- [9] Chao Xu, Dandan Liang, Shinya Sugiura, Soon Xin Ng and Lajos Hanzo, IEEE Transactions on Communications **61**, 1415 (2013).
- [10] Chen Ming, Xiao Jiangnan, Chen Lin, Cao Zizeng, Chen Jie, Wu Xian and Yan Guangwen, Journal of Optoelectronics-Laser **24**, 63 (2013). (in Chinese)