

## Research on electrical characteristic of discharge tube in ring laser gyro

Fan Zhenfang, Lu Guangfeng, Zhang Bin, Wang Zhiguo, Luo Hui

(College of Optoelectronic Science and Engineering, National University of Defense Technology, Changsha 410073, China)

**Abstract:** Ring laser gyro is usually pumped by high voltage discharge. Negative impedance characteristic of discharge tube can cause instability or oscillation of the current adjustment circuit. In order to optimize the discharge circuit loop, the impedance characteristic of discharge tube in ring laser gyro was researched. The voltage drop was measured under different discharge current, and voltage-current characteristic was obtained through nonlinear curve fitting. And then differential impedance, which was related to adjustment stability, was analyzed. The research can provide guidance for selection of ballast resistor and reduce the power consumption on premise of reliability.

**Key words:** ring laser gyro; discharge tube; negative impedance

**CLC number:** TN249    **Document code:** A    **DOI:** 10.3788/IRLA201746.0605002

## 环形激光陀螺放电管电学特性研究

樊振方, 卢广锋, 张斌, 汪之国, 罗晖

(国防科学技术大学 光电学院, 湖南 长沙 410073)

**摘要:** 激光陀螺通常采用高压直流来提供泵浦。放电管的负阻特性会引起稳流回路的不稳定或震荡。为了优化放电环路, 研究了放电管的阻抗特性。测量了不同放电电流下的管压降, 通过多项式拟合得到了放电管的伏安特性曲线。由于微变阻抗直接决定了环路的稳定性, 重点分析了微变阻抗随着电流的变化规律。研究可以为镇流电阻的选择和放电环路的优化设计提供参考, 可以降低功耗并提高电路的可靠性。多样本测试表明文中的结论具有普遍适用性。

**关键词:** 环形激光陀螺; 放电管; 负阻抗

收稿日期: 2016-10-05; 修订日期: 2016-11-03

基金项目: 国家自然科学基金(61308059)

作者简介: 樊振方(1984-), 男, 讲师, 博士, 主要从事激光陀螺信号处理方面的研究。Email: nudtfzj@126.com

## 0 Introduction

The ring laser gyro is a high accuracy angular movement sensitive device, which is used widely in strapdown inertial navigation systems<sup>[1-3]</sup>. Its basic principle is Sagnac effect; and it can convert the angular movement into beat frequency signal<sup>[4-9]</sup>. The basic configuration of ring laser gyro is a ring cavity, in which mixture gas of helium(He) and neon(Ne) are filled. The ratio of them is about 10:1, and the pressure is about 600-1 500 Pa. He is the real gain media, but it cannot be pumped to high energy level easily. Because high energy level of He and Ne match very closely, Ne is used to help the transition of He. That is, Ne atoms are pumped to the high energy level first, and then collision between atoms and cause energy transfer from He to Ne<sup>[10]</sup>. To avoid gain competition between the two beams travelling in opposite directions, mixed isotopes of Ne<sup>20</sup> and Ne<sup>22</sup> are usually used with ratio about 1:1<sup>[10-11]</sup>.

The atomic transition is stimulated by means of high voltage DC (Direct Current) discharge. The DC discharge must be maintained a constant current to ensure the performance of ring laser gyro. Therefore the electrical characteristic of discharge tube is of great significance, and it plays an important role in the control circuit design. This paper will analyze the characteristic of discharge tube as an electrical component.

Most electrical component has positive impedance and differential impedance. For a resistor, its impedance is a constant, and is positive. For a diode, its  $V-I$  characteristic can be described as:

$$I=I_S(e^{\frac{U}{U_T}}-1) \quad (1)$$

Where  $I_S$  is the reverse saturation current, and  $U_T$  is constant voltage, which is about 26 mV. The differential impedance of diode can be deduced as:

$$R_d=\frac{dU}{dI}=\frac{U_T}{I_S} \cdot e^{-\frac{U}{U_T}} \quad (2)$$

From Eq. (2), it can be concluded that the differential impedance of a diode is positive although it decreases with the voltage.

The discharge tube of ring laser gyro is different from the above mentioned electrical component. When the discharge current increases, the voltage drop decreases. This negative impedance characteristic will induce current overrun, and will distort the adjustment circuit and even generate oscillation in some cases. Therefore the electrical characteristic of discharge tube must be researched in order to design an accurate and steady discharge control loop. In this paper, the electrical characteristic of discharge tube in ring laser gyro is studied, firstly the  $V-I$  characteristic is obtained, and then the impedance and differential impedance is analyzed. The result will provide guidance in close loop control of discharge current and reduce the total power consumption on the premise of reliability.

## 1 Discharge structure of ring laser gyro

It is discovered that the DC discharge in the laser gyro cavity gives rise to gas circulation that is called Langmuir flow effect<sup>[12]</sup>. Along the center of discharge tube the atoms move towards the cathode, while along the wall of tube move toward the anode<sup>[7]</sup>. If the oppositely directed traveling waves see a net gas flow, a null shift, which depends on the magnitude and direction of the discharge current unbalance causing the net gas flow, will appear in the output of the gyro. The null shift is shown to be due to the mode pulling and pushing associated with the anomalous dispersion exhibited by the gain medium<sup>[7,12]</sup>. In order to overcome this problem, a symmetric discharge structure, as shown in Fig.1 is often used. There are two opposite discharge legs, each has one anode and the cathode is shared by both of them. Discharge current of the two legs must be strictly the same. In this manner the Langmuir flow effect of the two legs will be cancelled out.

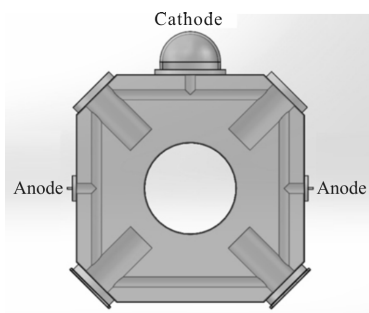

Fig.1 Discharge structure of ring laser gyro

Discharge servo circuit must be used to realize discharge control. Figure 2 shows the typical discharge control circuit of ring laser gyro. A high voltage of about  $-500\text{ V}$  is generated by high voltage generator made up of a DC/DC converter that transforms low voltage supply ( $+27\text{ V}$ ) into high voltage by a magnetic transformer. The current adjustment circuit is used to maintain constant current in discharge leg, and both legs must have the same current in order to overcome the null shift caused by the Langmuir flow effects<sup>[12]</sup>. Because the discharge tube has negative impedance characteristic, ballast resistor must be used to cancel out the negative impedance of the discharge tube. The high voltage level can be a constant voltage or change with the regulation signal of current adjustment circuit in the two legs, thus the power feedback section is optional.

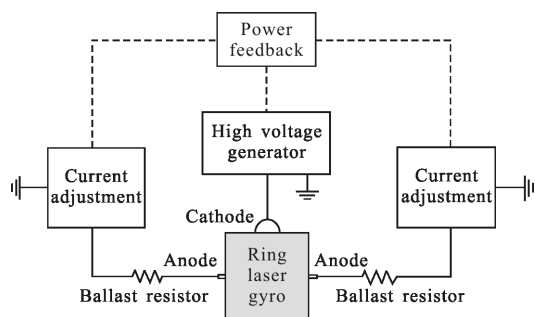

Fig.2 Discharge control circuit of ring laser gyro

## 2 Experiment and discussion

Research on electrical characteristic of discharge tube in ring laser gyro is vital for the design of discharge control circuit. Because the two legs of

discharge tube are symmetric, experiment on one side is representative. To obtain the impedance character, the current is set to different value, and then the voltage drop is measured, and the result is shown in Tab.1. The discharge length is about  $14\text{ cm}$ , the gas pressure is about  $800\text{ Pa}$ . Taking advantage of high reflective mirrors, the cavity loss can reach as low as  $300\text{ ppm}$ .

Tab.1 Voltage drop with different discharge currents

Current/mA	Voltage drop/V
0.2	392
0.3	361
0.4	352
0.5	345
0.6	341
0.7	336
0.8	333
0.9	328

In order to obtain the  $V-I$  characteristic, polynomial regression or curve fitting method is applied to the data in Tab.1. The order of the fitting is not determined, so higher order can be used first. If the residual error does not change greatly while the order is reducing, then the lower order can be used. After several attempts, the fitting model is chosen as:

$$U = a_1 * I + a_2 + a_3 * I^{-1} + a_4 * I^{-2} \quad (3)$$

Where  $a_1, a_2, a_3, a_4$  are the coefficients of the polynomial. After curve fitting, the coefficients in Eq.(3) can be obtained as

$$\begin{aligned} a_1 &= -55.5\text{ V/mA} \\ a_2 &= 391.4\text{ V} \\ a_3 &= -16.77\text{ V} \cdot \text{mA} \\ a_4 &= 3.81\text{ V} \cdot (\text{mA})^2 \end{aligned} \quad (4)$$

The experimental data and fitting curve are both drawn in Fig.3, in which points signed with '\*' are the data in Tab.1 and the solid line is polynomial in Eq.(3). It is shown that the fitting is preferably and the residual error is very small.

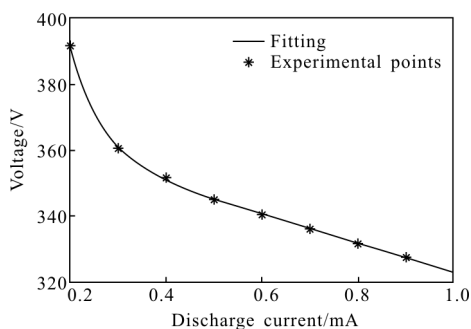

Fig.3 Voltage-current characteristic of discharge tube

According to Eq.(4), the impedance of the discharge tube is:

$$R = \frac{U}{I} = a_1 + a_2 \cdot I^{-1} + a_3 \cdot I^{-2} + a_4 \cdot I^{-3} \quad (5)$$

Differential impedance will be deduced by taking differential of Eq.(3):

$$R_d = \frac{dU}{dI} = a_1 - a_3 \cdot I^{-2} - 2a_4 \cdot I^{-3} \quad (6)$$

By using the coefficients in Eq.(4), the curve of impedance and differential impedance with current can be drawn in Fig.4. When the current is relatively large in Eq.(6), the last two term can be neglect, and then:

$$R \approx a_1 \quad (7)$$

In such case the discharge tube can be equivalent to a resistor whose impedance value is negative. From the fitting result in Eq.(4), it can be deduced that the impedance value is  $-55 \text{ k}\Omega$  when the current is a large value.

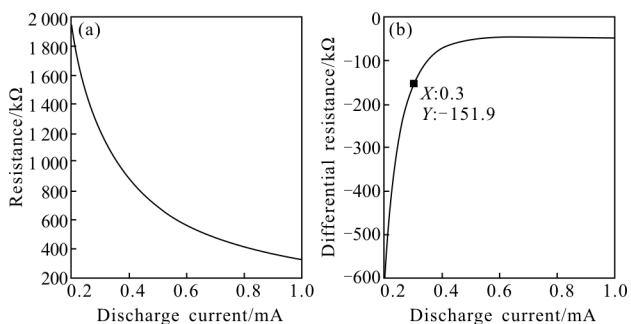

Fig.4 Impedance and differential impedance of discharge tube

Differential impedance reflects the impedance variation with discharge current. In the current control loop, the differential impedance is of great

importance, since it determines the stability of the loop. In order to ensure the reliable operation of current adjustment circuit, the negative impedance must be cancelled out. The direct way is to add a ballast resistor, but its value must be chosen properly. If the ballast resistor is too small, the negative impedance of the discharge tube cannot be offset and oscillation may occur in control loop. If value of ballast resistor is very large, extra power is dissipated in the ballast resistor, which will increase the total power consumption of the ring laser gyro. The discharge current of every leg is often chosen between 0.4–1 mA in ring laser gyro. From Fig.4(b), it could be observed that when the current is lower, the absolute value of negative impedance is large, so the lower boundary 0.4 mA is much important. From Fig.2 we can see that when the current is 0.3 mA, the differential impedance is about  $-151.9 \text{ k}\Omega$ , so a ballast resistor of  $160 \text{ k}\Omega$  is chosen, and in this case, the current adjustment circuit can work safely in the range of 0.4–1 mA.

After experiment on other gyros that have the same geometry structure and size, it is shown that the result is similar with Fig.3 and Fig.4. Therefore the result in this research can be applied to all the gyros with the path length of 28 cm.

### 3 Conclusion

Discharge tube of ring laser gyro exhibits negative impedance characteristic. This characteristic will disorder the current adjustment circuit, and will cause oscillation of the control loop. The electric characteristic of the discharge tube is researched experimentally. By applying linear fitting to the experimental data, the  $V-I$  characteristic is obtained. From the analyses of the differential impedance under different current, it is concluded that the best ballast resistor for this type of ring laser gyro is about  $160 \text{ k}\Omega$ , that can ensure the gyro work safely in the range of 0.4–1 mA and does not take extra power consumption.

**References:**

- [1] King A D. Inertial navigation-forty years of evolution[J]. *GEC Review*, 1998, 13(3): 140-149.
- [2] Fan Z, Luo H, Lu G, et al. Online effective backscattering estimation for ring laser gyro [J]. *Chinese Optics Letters*, 2012, 10(9): 51404. (in Chinese)
- [3] Fan Z, Luo H, Lu G, et al. Dynamic lock-in compensation for mechanically dithered ring laser gyro [J]. *Chinese Optics Letters*, 2012, 10(6): 61403. (in Chinese)
- [4] Mengozzi L N, Lamb W E. Theory of a ring laser[J]. *Physical Review A*, 1973, 8(4): 2103-2125.
- [5] Wilkinson J R. Ring lasers [J]. *Progress in Quantum Electronics*, 1987, 11(1): 101-103.
- [6] Post E J. Sagnac effect[J]. *Reviews of Modern Physics*, 1967, 39(2): 475-493.
- [7] Chow W W. The ring laser gyro [J]. *Reviews of Modern Physics*, 1985, 57(1): 61-104.
- [8] Faucheux M, Fayoux D, Roland J J. The ring laser gyro [J]. *Journal of Optics*, 1988, 19(3): 101-115.
- [9] Kogelnik H, Li T. Laser beams and resonators[J]. *Proceedings of the IEEE*, 1966, 54(10): 1312-1329.
- [10] Siegman A E. Lasers [M]. Mill Valley: University Science Books, 1986.
- [11] Aronowitz F. Fundamentals of the ring laser gyro[R], 1999.
- [12] Podgorski T J, Aronowitz F. Langmuir flow effects in the laser gyro [J]. *IEEE Journal of Quantum Electronics*, 1968, 4(1): 11-18.