

Stable single-mode operation of injection-seeded Q -switched Nd:YAG laser by sine voltage modulation

Yongfei Gao (高永飞)^{1,3}, Junxuan Zhang (张俊璇)^{1,2}, Huaguo Zang (臧华国)¹, Xiaolei Zhu (朱小磊)^{1,*}, Yingjie Yu (于瀛洁)³, and Weibiao Chen (陈卫标)¹

¹Key Laboratory of Space Laser Communication and Detection Technology, Shanghai Institute of Optics and Fine Mechanics, Chinese Academy of Sciences, Shanghai 201800, China

²University of Chinese Academy of Sciences, Beijing 100049, China

³Shanghai University, Shanghai 201800, China

*Corresponding author: xlzhu@siom.ac.cn

Received January 17, 2016; accepted April 22, 2016; posted online May 30, 2016

Based on the modified ramp and fire technique, a novel injection seeding approach with real-time resonance tracking is successfully demonstrated in a single-frequency Nd:YAG pulsed laser. Applying a high-frequency sinusoidal modulation voltage to one piezo actuator and an adjustable DC voltage to another piezo actuator for active feedback, single-mode laser output with high-frequency stability is obtained, and the effect of the piezo hysteresis on the frequency stability can be eliminated for a laser diode pumped Q -switched Nd:YAG laser at a repetition rate of 400 Hz.

OCIS codes: 140.3425, 140.3570, 140.3538.

doi: 10.3788/COL201614.071401.

High-energy, single-longitudinal mode (SLM) pulsed lasers with high spectrum stability are required for a wide variety of applications. Examples are laser trapping, nonlinear frequency conversion^[1], resonant laser ionization mass spectroscopy, high-resolution spectroscopy, and various lidar systems such as high spectral resolution lidar (HSRL), Doppler wind lidar^[2], and differential absorption lidar (DIAL) for detecting the concentrations of trace gases with narrow absorption spectrum lines. The spectrum characteristics of a laser pulse, such as the spectral linewidth and the frequency stability, will directly influence the measurement accuracy and the detection capability. One of the most efficient methods to obtain SLM output from a Q -switched pulsed laser is injection seeding. According to the basic principles of the injection seeding method^[3], in order to obtain a highly reliable injection seeded process, the slave laser cavity length should be in resonance critically with the seeder laser frequency at the time of the laser pulse emission. This process usually can be realized while an active locking scheme is introduced, where an input signal should be fed into a stabilization loop to generate a signal used to control the cavity length, mostly by means of one piezo actuator fixed with a rear mirror. The crucial parameter for injection seeding process control is not the absolute cavity length, but the phase shift between the seeder laser beams; one beam that is entering the cavity first, and another beam that is after one round trip inside the cavity. The resonance signal is given once the phase shift is zero, so it is very important to apply a fast scan voltage to control the slave cavity length. For those well-used methods of seeder injection adopting a triangular scan ramp voltage, such as buildup time minimizing^[4], ramp fire^[5], ramp hold fire^[6], delay ramp fire^[7], and modified Pound–Drever–Hall (PDH)^[8], all are

sensitive to the effect of higher-frequency vibration noise, are difficult to increase the operation rate of the seeded single frequency laser, and usually need to apply hundreds of volts of scanning voltage on the piezo actuator, which means higher energy consumption is needed. In 2005, Ertel described an injection-seeded pulsed Ti:sapphire laser with a stabilization scheme, and the modulation voltage consisted of a sinusoidal wave with a fixed amplitude and an adjustable DC offset^[9], which successfully avoided the rapid motions of the piezo-mounted rear mirror.

In this Letter, based on the modified ramp-fire technique^[10] and the real-time resonance tracking method on an injection-seeded Q -switched Nd:YAG laser^[11], a novel stabilization design with a sinusoidal driven voltage on one piezo-mounted rear mirror and an adjustable DC offset voltage for feedback on another piezo-mounted rear mirror of the slave cavity is introduced, and stable single-longitudinal-mode laser emission with 0.50 MHz (RMS) frequency jitter was achieved from a laser diode (LD) end-pumped Q -switched Nd:YAG laser.

The two rear mirrors of the slave laser oscillator are independently mounted on two pieces of piezoelectric ceramics. Since one piezo actuator is driven by a sinusoidal scan voltage for cavity length control, and another one is modulated by an adjustable DC voltage for feedback, the expressions for the interference signal intensity I and the phase are

$$I = I_1 + I_2 + 2\sqrt{I_1 I_2} \cos(2\pi\delta + 4\pi\alpha((A \sin(2\pi kt) - B)/\lambda)), \quad (1)$$

$$\text{phase} = 2\pi\delta + 4\pi\alpha(A \sin(2\pi kt) - B)/\lambda, \quad (2)$$

where I_1 and I_2 are the intensities of two light beams of the seeder, δ is the offset between the optical length of the resonant cavity relative to seeder frequency matching length, α is the response coefficient of the piezo ceramic, A is the amplitude of the sinusoidal voltage, k is the frequency of the sinusoidal scanning voltage, and B is the offset DC voltage for feedback.

The interference signal reaches its maximum value at the condition of phase $= 2k\pi$ ($k = 0, 1, 2, \dots$), which is called the resonance condition of the slave cavity with the injection seeder light. In order to obtain the peaks of the interference signal at any phase offset, a suitable sinusoidal scanning voltage amplitude A should be selected so that the cavity length could match well with the seeder laser frequency. Even more, in order to obtain a stable output power, the event of the maximum value detection of the interference signal should happen at a certain time during every scanning period and the laser shot time is fixed; an appropriate feedback voltage should be applied to counteract the time difference between the actual position and the theoretical point caused by the disturbances. The feedback DC voltage is given as

$$B = A \sin(2\pi k \Delta t), \quad (3)$$

where Δt is the time difference between the actual position of the rear mirror with the theoretical anticipation position.

As sketched in Fig. 1, the novel sinusoidal voltage scanning and DC offset voltage feedback control unit used in the experiment consists of the following three sections: a homemade digital electronic loop (a circuit board with a field-programmable gate array chip as the core), two high-voltage (HV) amplifiers (10 times magnification) that are capable of outputting more current to drive the lead zirconate titanates (PZTs), and a PIN photodiode with high performance used as the photodetector. The principle of the cavity length controlling is depicted in Fig. 2.

First, the active modulation of the optical path length of the slave cavity is done by PZT1(M1), which is driven by a sine wave voltage (amplitude is 15 V) at a repetition rate of 10 kHz. Due to the nonlinear effect of the piezoelectric ceramics^[12], it is necessary that, at the rising edge of every transistor-transistor logic (TTL) trigger signal that is synchronized with the pump source, the initial phase of the sinusoidal drive voltage be set to zero for each

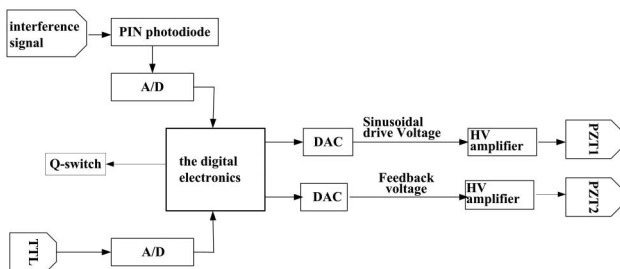

Fig. 1. Frame diagram of the cavity length control unit.

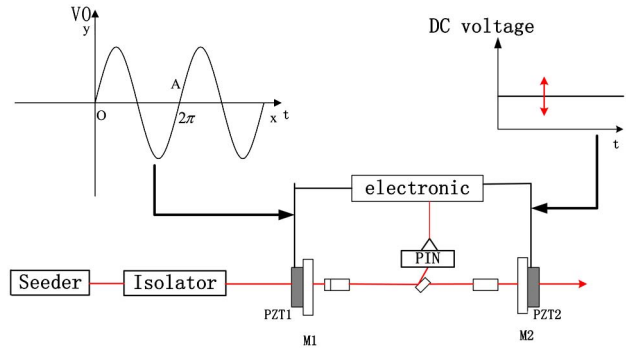

Fig. 2. Cavity controlling approach with the sine wave.

scanning cycle. The benefits from the stable and almost coincident ramp process of PZT1 in every scanning period are that the effect of the piezo hysteresis on the frequency stability is eliminated. In addition, due to adopting a sinusoidal scanning signal with a 10 kHz repetition frequency, this injection seeding process is insensitive to a certain range of vibration noises.

Second, the photodiode (PIN, in Fig. 2) converts the detected interference light signal into an electrical signal in real time, and the digital electrical board continuously monitors the resonance signals and records the time of each resonance peak appearance. Here, by comparing the time of the first resonance peak within 50 to 100 μs with 90 μs , which is set as a reference time point, we can get the value of the time difference Δt , then apply an optimized DC offset voltage to PZT2(M2) to ensure that a resonance peak could occur at the time of 190 μs delay to the TTL trigger signal of the pump source. The Q -switch is fired once the resonance peak near 190 μs is detected. The DC offset voltage should be adjusted before every laser shot to make the stabilize the resonance peak at a fixed time point of the sinusoidal drive wave. Since the pulse duration of the pump LDs is ensured to be equal before the Q -switch is being fired, stable laser pulse energy is finally obtained by this approach. Even more, due to the symmetry of the sinusoidal drive wave, the value of the ramp voltage could be reduced greatly compared with that of triangular scanning.

Stable single-frequency laser pulse output was demonstrated in an LD-pumped Q -switched Nd:YAG laser. The seeder laser for injection seeding is a homemade non-planar ring oscillator (NPRO) Nd:YAG laser operating at 1064 nm with a maximum output of 350 mW. The length of the slave cavity is approximately 450 mm with an equivalent free spectral range of 330 MHz. The gain rod is dual-end-pumped by two LDs with maximum output peak power of 150 W for each. The composite Nd:YAG crystal ($\Phi 4 \text{ mm} \times 30 \text{ mm}$), which is designed to reduce the thermal lensing effect, includes a 20 mm 0.3% Nd³⁺-doped YAG crystal sandwiched by two 5 mm undoped YAG crystals. A pair of rubidium titanyle phosphate crystals (6 mm \times 6 mm \times 10 mm each), combined with a polarizer and a quarter-wave-plate (QWP), act as an electro-optical Q -switch. The slave cavity arrangement can be

seen in our previous Letter^[10]. The output pulse energy was 0.8 mJ at a pulse repetition rate of 400 Hz. The laser pulse temporal profile, shown in Fig. 3, was detected by a 1.3 GHz bandwidth InGaAs photodiode and recorded by a Tektronix TDS3054 oscilloscope at a bandwidth of 500 MHz. The pulse width was about 27 ns. The smoothly temporal profile of the injection-seeded laser pulse indicated that single-frequency laser output was achieved.

In our experiments, the optical heterodyne technique was adopted to measure the frequency jitter of this injection seeded *Q*-switched laser. Another 1064 nm Nd:YAG NPRO single-frequency CW laser (Mephisto OEM200, Innolight GmbH) was used as an offset local oscillator for the optical heterodyne technique. The frequency difference between the CW laser and the measured pulsed laser was approximately 155 MHz. The data was sampled and saved by a 1.3 GHz bandwidth photodiode and a 600 MHz oscilloscope (LeCroy WaveRunner 62Xi 10 GS/s). The spectral linewidth of the injection seeded pulsed laser at 1064 nm was finally derived by a fast Fourier transform (FFT) algorithm of the heterodyne beat signal. Figure 4 is the spectrum of the beat signal detected; it reveals that the full width at half-maximum (FWHM) of the laser spectrum linewidth of about 18 MHz has been obtained. Considering the pulse duration of 27 ns, as shown in Fig. 3, a nearly Fourier-transform-limited laser pulse output has been achieved. These results revealed that a stable SLM laser output has been achieved with a modulation of sinusoidal voltage.

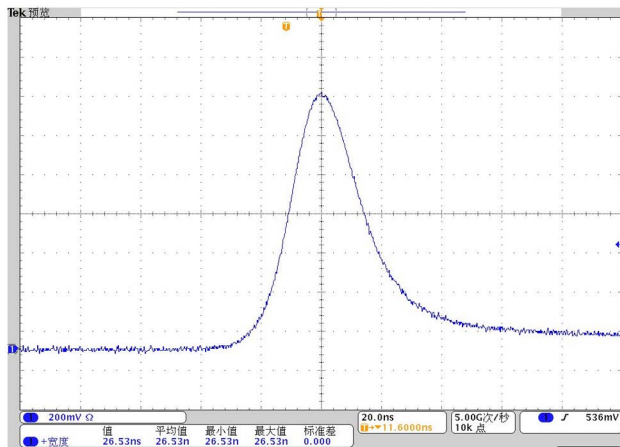

Fig. 3. Pulse trace of the laser pulse.

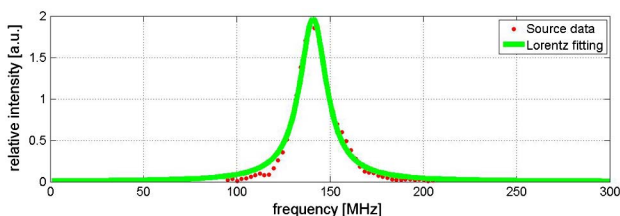

Fig. 4. Spectrum of the beat frequency signal.

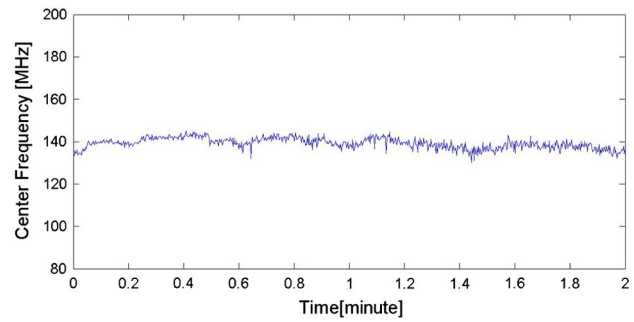

Fig. 5. Frequency stability over 2 min.

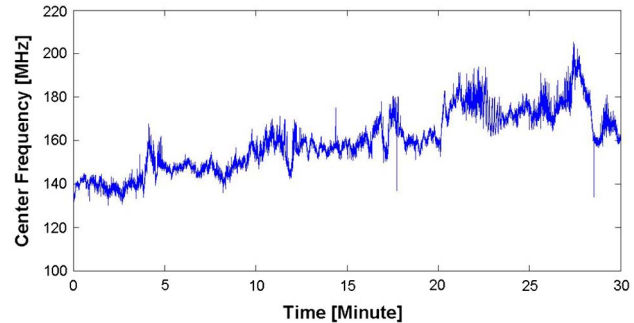

Fig. 6. Frequency stability over 30 min.

As the measurement results illustrated in Fig. 5, when the active feedback was turned on, the minimum shift of the beat frequency around 0.50 MHz (RMS) could be achieved over 2 min, but when the active feedback was turned off, the minimum shift of the beat frequency increased to 3.58 MHz (RMS) in 2 min. So a significant increase of frequency stability was demonstrated with an adjustable DC voltage feedback unit. We also measured the frequency jitter over 30 min, and it was less than 9.1 MHz (RMS). The detected curve is illustrated in Fig. 6. In our previous work of an injection seeded laser using triangular voltage modulation with active feedback in a similar cavity arrangement, the frequency jitter was as large as 3.5 MHz (RMS) over 2 min^[10]. It has been proven that using the real-time resonance tracking method with a sinusoidal voltage scanning and adjustable DC offset feedback the stability of the frequency of the injection seeded pulsed laser can be increased considerably.

In conclusion, a novel real-time resonance tracking method with a sinusoidal voltage drive wave and adjustable DC offset voltage feedback is developed, and a stable single-frequency laser output is successfully realized in an injection-seeded LD end-pumped Nd:YAG pulsed laser when a high-frequency sinusoidal drive wave is applied to the PZT. This injection seeded laser is capable of outputting an SLM laser pulse with a high-frequency stability and nearly Fourier-transform-limited spectral linewidth. It is believed that this laser system is more suitable for Doppler lidar application for continuous wind measurements.

References

1. H. Li, X. Zhu, X. Ma, S. Li, and C. Chen, *Chin. Opt. Lett.* **13**, 111402 (2015).
2. W. Diao, X. Zhang, J. Liu, X. Zhu, Y. Liu, D. Bi, and W. Chen, *Chin. Opt. Lett.* **12**, 072801 (2014).
3. Y. K. Park, *IEEE J. Quantum Electron.* **20**, 117 (1984).
4. L. A. Rahn, *Appl. Opt.* **24**, 940 (1985).
5. S. W. Henderson, E. H. Yuen, and E. S. Fry, *Opt. Lett.* **11**, 715 (1986).
6. T. Walther, M. P. Larsen, and E. S. Fry, *Appl. Opt.* **40**, 3046 (2001).
7. J. Zhou, H. Zang, T. Yu, J. Liu, and W. Chen, *Proc. SPIE* **681**, 66810R (2007).
8. A. Sträßer, T. Waltinger, and M. Ostermeyer, *Appl. Phys.* **46**, 8358 (2007).
9. K. Ertel, H. Linné, and J. Bösenberg, *Appl. Opt.* **44**, 5120 (2005).
10. J. Wang, R. Zhu, J. Zhou, H. Zang, X. Zhu, and W. Chen, *Chin. Opt. Lett.* **9**, 081405 (2011).
11. X. Xu and J.-C. Diels, *Appl. Phys. B* **114**, 579 (2014).
12. N. Ise, K. Takaya, and H. Hirohara, *J. Phys. III*, **7**, 1197 (1997).