

Fifty-five km reach, bidirectional, 400 Gb/s (40 × 10 Gb/s), channel-reuse DWDM-PON employing a self-wavelength managed tunable laser

Zhiguo Zhang (张治国)*, Xu Jiang (蒋旭), Jiahe Wang (王佳和),
Xue Chen (陈雪), and Liqian Wang (王立芊)

State Key Laboratory of Information Photonics and Optical Communications,
Beijing University of Posts and Telecommunications, Beijing 100876, China

*Corresponding author: zhangzhiguo@bupt.edu.cn

Received September 7, 2014; accepted December 22, 2014; posted online February 10, 2015

We experimentally demonstrate a channel-reuse bidirectional 10 Gb/s/λ long-reach dense wavelength-division multiplexing passive optical network (DWDM-PON) and an optical beat-noise-based automatic wavelength control method for a tunable laser used in a colorless optical network unit (where λ = wavelength). A 55 km, bidirectional, 400 Gb/s (40 × 10 Gb/s) capacity channel-reuse transmission with 100 GHz channel spacing is achieved. The transmission performance is also measured with different optical signal to Rayleigh backscattering noise ratios and different central wavelength shifts between upstream and downstream in the channel-reuse system.

OCIS codes: 060.4510, 060.4250.

doi: 10.3788/COL201513.020603.

Wavelength-division multiplexing (WDM) passive optical networks (PONs) have been regarded as a promising solution for next-generation optical access networks in terms of high security, easy maintenance, great flexibility, as well as broad bandwidth^[1–4]. Driven by ever-increasing user demands for broadband services to support high-quality Internet Protocol Television (IPTV), Internet-based learning, interactive games, and advanced peer-to-peer multimedia services, it is expected that the data rate demand will continuously grow and numerous access nodes will be deployed over the next decades. Due to the continuous growth of new services that use high bandwidths, WDM-PON access networks will migrate to hundreds of gigabits of system capacity in the near future^[5–7]. In addition, supporting longer-reach and larger splits is also expected^[8–12]. As 10 Gb/s per channel will be one of the typical channel rates of WDM-PONs in the near future^[13–15], the main challenge when increasing the total system capacity of 10 Gb/s per channel WDM-PON consists of improving the spectral efficiency. Narrow channel-spacing and channel-reuse techniques are promising solutions to increase the total system capacity of 10 Gb/s per channel for WDM-PON.

One important issue for WDM-PON is the low-noise, cost-effective colorless optical source in the optical network unit (ONU). Various colorless optical sources have been proposed, including a reflective semiconductor optical amplifier (RSOA), semiconductor optical amplifier (SOA) reflective electro-absorption modulator (REAM), and tunable laser diodes (TLDs)^[16–18]. Rayleigh backscattering noise is another important issue for a channel-reuse WDM-PON scheme^[19–22], especially for loopback-mode-based wavelength-reuse systems^[23,24]. As the wavelength

of the upstream optical carrier can be set to be flexible and the central wavelengths of upstream and downstream can be mismatched, a TLD-based, colorless optical source is an attractive solution with a low Rayleigh backscattering noise effect for a channel-reuse WDM-PON system. However, an automatic wavelength-control method for a tunable laser is needed to realize true colorless operation with a plug-and-play feature. To use the Rayleigh backscattering effect is one proposal to solve this problem^[25]. However, the control accuracy will degrade as the length of the drop fiber increases. These current solutions either cannot effectively perform the initial wavelength setting or increase the system cost.

In the Letter, we propose a TLD-based, channel-reuse, bidirectional, 10 Gb/s/λ, long-reach, dense WDM (DWDM)-PON scheme. Also, an optical beat-noise-based automatic wavelength control method using a downlink optical signal to manage the wavelength of the TLD in colorless ONU is proposed. A 55 km reach, channel-reuse, bidirectional, 400 Gb/s (40 × 10 Gb/s) capacity transmission using a Mach-Zehnder modulator (MZM) modulator and direct detection (DD) receiver is experimentally demonstrated with 100 GHz channel spacing. Transmission performance is also measured with different optical signal to Rayleigh backscattering noise ratios (OSRBNRs) and different central wavelength shifts (WSs) between upstream and downstream in the channel-reuse system.

Figure 1 shows the proposed TLD-based WDM, channel-reuse, bidirectional, 10 Gb/s/λ, long-reach DWDM-PON scheme. The optical line terminal (OLT) consists of n optical transceivers constituted by n on-off keying (OOK) intensity modulation (IM) transmitters

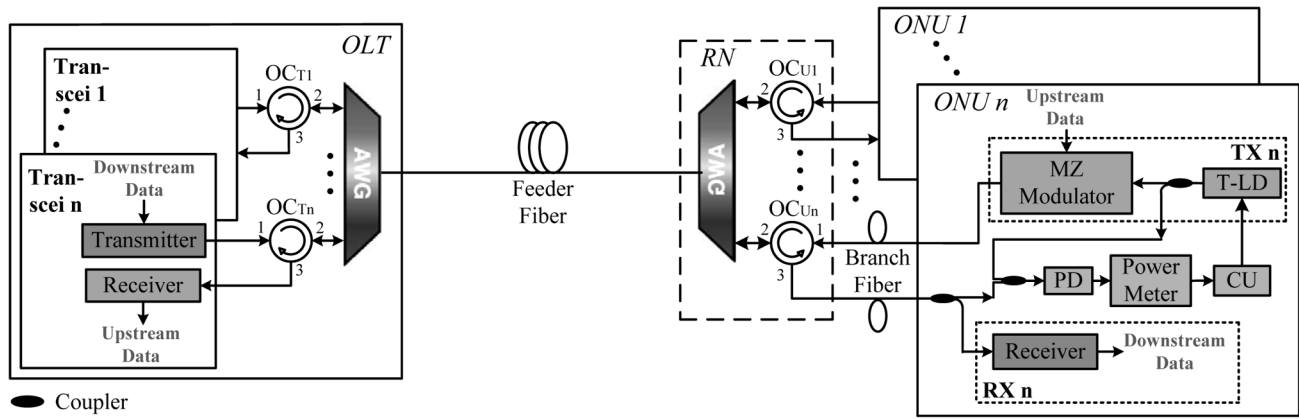

Fig. 1. Proposed channel-reuse, long-reach DWDM-PON architecture.

and DD receivers, n three-port optical circulators (OC_{Tn}), and one $n \times 1$ array waveguide grating (AWG). In the remote node (RN), one $n \times 1$ AWG and n three-port OCs (OC_{Un}) are used to couple n ONUs. In one ONU, the uplink transmitter consists of a TLD and an external optical modulator. The downlink receiver is a DD receiver. An optical beat-noise-based automatic wavelength-control method using the downlink optical signal to manage the wavelength of the TLD is also designed to initialize the wavelength setting of the TLD in the ONU. Part of the uplink carrier light and part of the downlink signal light are coupled into a photo-detector (PD) using three 2×2 optical couplers. Then, the optical beat noise between the uplink carrier light and the downlink signal light is generated at the PD. The noises power is measured by a microwave power meter and is sent to a control unit (CU). The wavelength of the TLD output carrier light is controlled by the CU to match the wavelength of the downlink optical signal.

In order to verify the feasibility of the optical beat-noise-based automatic wavelength-control method, we have experimentally measured the optical beat noise powers between the downlink optical signal and the output light of a wavelength continuously TLD (CTLTD) in various central WS cases. Figure 2 shows the experimental setup and the picture of the experimental platform. A 10.3125 Gb/s, pseudo-random bit sequence (PRBS) OOK optical signal is generated by a DWDM grid tunable optical transmitter (Finisar FTLX4213). The optical

signal then is sent to one input port of a 3 dB optical coupler via an AWG and a variable optical attenuator (VOA, i.e., VOA1). Light output of a power-tunable CTLTD (SoutherPhotronics TLS150) with a 6–16 dBm output power range is sent to another input port of the 3 dB optical coupler via VOA2. Then, the optical beat noise is generated at a PD (1 GHz) and is measured by a microwave power meter (Agilent N1911a). The beat noise power value is sent to a CU that consists of a computer and control software through a GPIB interface. The control software consists of microwave power receiving and recording module, microwave power data processing module, and TLD control module. The output wavelength of the CTLTD is controlled by the TLD control module in the CU using a USB interface to match the wavelength of the downlink optical signal.

After powering on, the CTLTD is enabled and the operation wavelength is set to an initial wavelength λ_0 . The CTLTD will run a t_{wait} time with the operation wavelength λ_0 . The microwave power receiving and recording module in the control software will periodically read the measured microwave power from the microwave power meter. Powers comparison between the measured microwave power and a threshold power will be implemented in the data processing module. The TLD control module will keep the λ_0 as the final operation wavelength if the measured beat noise power is greater than the threshold power. Otherwise, the operation wavelength of the CTLTD will be changed and a DWDM channel spacing wavelength

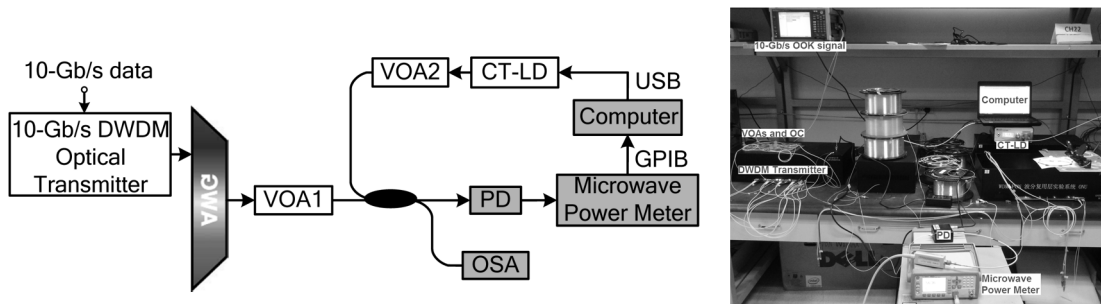

Fig. 2. Experimental setup and picture of beat noise power test platform.

change will be implemented under the control of the TLD control module at the end of t_{wait} . This operation will be sustained until the measured beat noise power is greater than the threshold power.

For practical applications and to be cost-effective, a PD with lower bandwidth (such as 300 MHz) can be used to limit the measured beat noise bandwidth and reduce the cost. The microwave power meter can be replaced by a low-cost diode microwave average power detector and signal detecting circuit. The CU should be a simpler and low-cost single-chip microcomputer-based control system.

In our work, the bandwidth of the 10.3125 Gb/s OOK signal generated by the 100 GHz DWDM optical transmitter is about 10 GHz and the linewidth of the output of the CTLD is about 1 MHz. The output optical powers of the VOA1 and VOA2 are set at -18 and -2 dBm, respectively, based on the actual power conditions in the proposed DWDM-PON scheme. The noise powers then were measured by the microwave power meter with a frequency setting of 300 MHz. Figure 3 shows the measured microwave power result. The result shows that the noise power is about -36 dBm when the central WS is more than 0.4 nm, higher than -33 dBm when the central WS is less than 0.15 nm, and 3 dB higher than the noise power as the central WS is more than 0.4 nm. Therefore, the CU can accurately determine that the two wavelengths are the same or not the same, based on the optical beat noise power measured by the microwave power meter. Moreover, the CU can also set or change the central WS in one 100 GHz DWDM channel based on the optical beat noise power. In addition, considering the length of the time of the beat noise power detection is less than 1 ms, the length of time of the data processing in computer is also less than 1 ms, and the tuning period per single adjustment of the CTLD is less than 10 ms; as a result, the total length of time to discover the downlink optical signal wavelength is less than 2 s even if the number of the DWDM channels is up to 40 .

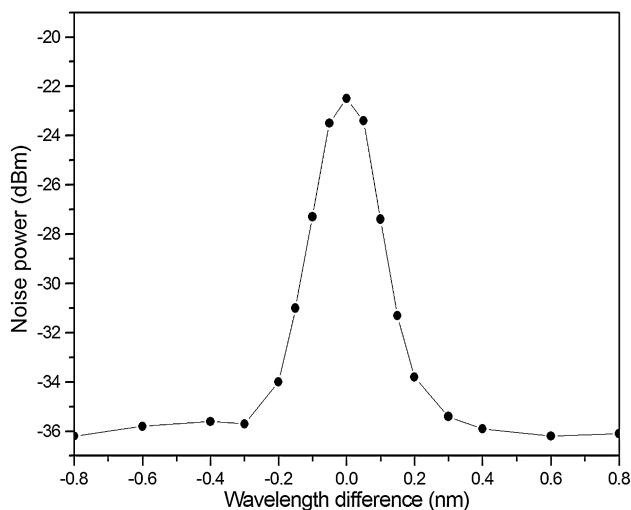

Fig. 3. Optical beat noise power versus central WSs.

For practical applications, the TLD and the MZM in Fig. 1 can be replaced by a tunable directly modulated laser (TDML) or a tunable electroabsorption-modulated laser (TEML). We also experimentally verify the feasibility of the optical beat-noise-based automatic wavelength-control method for an un-modulated or modulated TEML. In our work, the only change of the experimental setup (Fig. 2) is that the CTLD is replaced by a DWDM grid tunable optical transmitter (Finisar FTLX4213) with same optical power output. In the un-modulated case, the operation wavelength of the uplink optical carrier transmitted by the tunable optical transmitter will be adjusted channel-by-channel under the control of the computer while keeping the transmitter un-modulated. The measured result shows that the noise power is about -36 dBm when the two wavelengths are not in one DWDM channel. It is higher than -24 dBm when two wavelengths are in one DWDM channel, about 12 dB higher than the beat noise power as the two wavelengths are not in one DWDM channel. In the modulated case, the wavelength of the upstream transmitted by the tunable optical transmitter will be adjusted channel-by-channel under the control of the computer while keeping the transmitter modulated. The measured result shows that the noise power is about -22 dBm when the two wavelengths are not in one DWDM channel. It is higher than 21.5 dBm when two wavelengths are in one DWDM channel, only 0.5 dB higher than the beat noise power as the two wavelengths are not in one DWDM channel. Therefore, the optical beat-noise-based automatic wavelength control method can be used to effectively set the operation channel of TDML or TEML in the un-modulated case. It is a little difficult to use this wavelength control method in the modulated case because there is only a 0.5 dB microwave power difference. Furthermore, the central WS between upstream and downstream in one 100 GHz DWDM channel can also be accurately set or changed keeping the TDML or TEML un-modulated, as the same result of optical beat noise power versus central WS (shown in Fig. 3) can be achieved in TDML-based or TEML-based WDM-PON.

Figure 4 shows the experimental setup of the channel-reuse, bidirectional, 400 Gb/s capacity DWDM-PON with a 55 km standard single-mode fiber (SSMF). In the downlink direction of the DWDM channel k , 10.3125 Gb/s downlink OOK signals are generated by a DWDM grid tunable optical transmitter (Finisar FTLX4213) with an available operation wavelength from 1528.38 to 1560.61 nm and an average output power of 2 dBm. The OOK signal then is sent to the 50 km feeder SSMF via one three-port OC (OC_k) and a 40 channel AWG with overall about 4 dB insertion loss. After transmission over the 50 km feeder SSMF, the downlink OOK signal is sent to a error detector via another 40 channel AWG, an OC (OC_{Uk}), a 5 km branch fiber, and one 90:10 optical coupler with overall about 6 dB insertion loss. The bit-error ratio (BER) is then measured by the error detector. In the uplink direction of the channel k ,

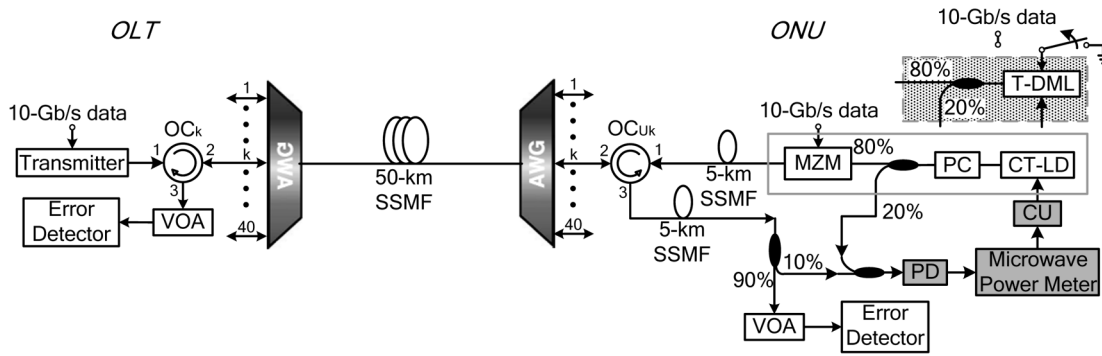

Fig. 4. Experimental setup for channel-reuse, bidirectional, 400 Gb/s DWDM-PON with 55 km SSMF transmission.

the optical output of a power-tunable CTLD (Souther-Photonics TLS150) with a 6–16 dBm output power range is sent to the MZM with 4 dB insertion loss via a polarization controller (PC) and an 80:20 optical coupler. A 10.3125 Gb/s OOK optical signal is generated and sent to the 50 km feeder SSMF via a 5 km branch fiber, one OC (OC_{Uk}), and an AWG with overall about 7 dB insertion loss. After transmission over the 50 km feeder SSMF, the upstream signal is fed into a VOA via an AWG and one OC (OC_k) with overall about 4 dB insertion loss. Then the uplink signal in the channel k is sent to an error detector. Twenty percent of the CTLD output in the uplink direction and 10% of the downlink signal are coupled into a PD (1 GHz optical receiver) using a 50:50 optical coupler. The noise power is measured by a microwave power meter (Agilent N1911a). After powering on, the operation wavelength of the uplink optical carrier transmitted by the CTLD will be adjusted channel-by-channel under the control of the CU; the operation wavelength will be set at current channel if the noise power of current channel is 3 dB higher than the noise power at the unwanted channels.

For practical applications, the tunable laser and the MZM (Fig. 4) can be replaced by a TDML or a TEMPL. In this case, the operation wavelength of the uplink

optical carrier transmitted by the TDML or TEMPL can be adjusted channel-by-channel under the control of the CU while keeping the TDML or TEMPL un-modulated; the operation wavelength will be set at current channel if the beat noise power of current channel is 3 dB higher than the beat noise power at the unwanted channels. Then, the 10.3125 Gb/s OOK signal makes use of the TDML or TEMPL and the upstream transmission is implemented.

Because of the similarity of the characteristics of the total 40 channels, the measurement results show that the transmission performances of all the 40 channels are almost completely identical. The transmission performances of downstream and upstream in the back-to-back (BTB) configuration and after 55 km transmission at Channel 20 are shown in Figs. 5(a) and 5(b). The bidirectional data rates of the nonreturn-to-zero (NRZ) OOK signal both are 10.3125 Gb/s with a $2^{31} - 1$ PRBS pattern length. In our work, the operation wavelength of the CTLD is set at 1545.32 nm in the wavelength passband of Channel 20, which is exactly identical with the operation wavelength of the transmitter of downlink at Channel 20. The output power of the power-tunable CTLD is set 9 dBm; as a result, the average output power of the MZM is about 2 dBm, keeping same with the average

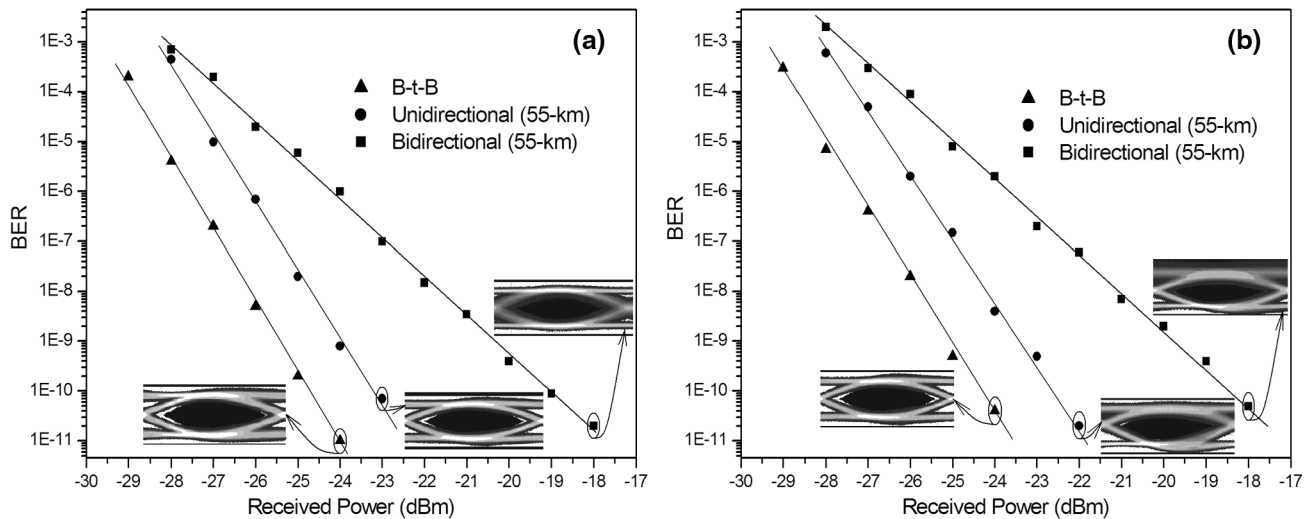

Fig. 5. Measured BERs at Channel 20 in the BTB configuration, after 55 km unidirectional and bidirectional transmissions; (a) downstream; (b) upstream.

output power of the downlink transmitter at Channel 20. Figure 5 shows that both the downlink and uplink have slight transmission penalties (1.5 dB) which originate from the chromatic dispersion and there are about 3.5 dB power penalties (at 1×10^{-9}) in the bidirectional transmission setup. Obviously, the power penalties originate from the Rayleigh backscattering noise as the optical wavelengths of the uplink and downlink is exactly identical in one DWDM channel.

In order to analyze the impact of the Rayleigh backscattering noise, which could worsen the optical signal noise ratio (OSNR) and reduce receiver sensitivity in a channel-reuse system, we measured the BER performances of bidirectional transmission with different central WS values and different OSRBNRs in one DWDM channel. The experimental setup remains unchanged as shown in Fig. 4. BER performances with different WS values are shown in Fig. 6. In this measurement, the average output powers of the downlink transmitter and uplink MZM at Channel 20 both remained at 2 dBm, unchanged. As a result, both the OSRBNRs at Port 3 of the OC_k and at Port 3 of the OC_{U_k} in Channel 20 remained at 23 dB, unchanged. The receiver sensitivities of upstream and downstream are -20 dBm at 1×10^{-9} and -20.5 dBm at 1×10^{-9} , respectively, when the central WS between uplink and downlink optical signals is 0 nm. Both the upstream and downstream receiver sensitivities will rapidly improve when the WS increases, then will reach -25 dBm at 1×10^{-9} when the central WS equals 0.08 nm. The receiver sensitivities are no longer increased significantly when the central WS is more than 0.08 nm. Therefore, the Rayleigh backscattering noise impact can be effectively reduced by mismatching the wavelengths of upstream and downstream in the channel-reuse system; the larger the WS, the smaller the Rayleigh backscattering noise effect. For our proposed channel-reuse DWDM-PON system, an intentional central WS can be set based on the measured result between the beat noise power and central WS.

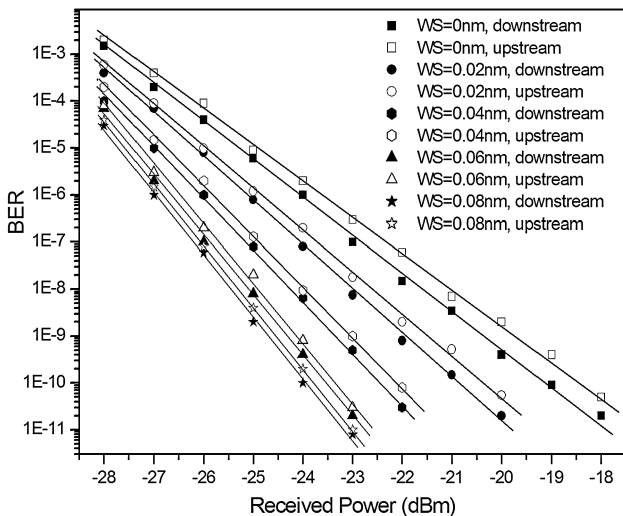

Fig. 6. BERs with different WSs.

The BER performances with different OSRBNR are also measured to assess the impact caused by different Rayleigh backscattering noise power while optical signal power remains constant in the same transmission direction. Considering the symmetry and similarity between upstream and downstream in this proposed system, we only measure the BER performances of the downstream. In our measurement, the downstream optical power at Port 3 of the OC_{U_k} in Channel 20 remains at -16 dBm, unchanged; the Rayleigh backscattering noise power in the downlink direction is changed by adjusting the output power of the power-tunable CTLD. The Rayleigh backscattering noise power in the downlink direction can be measured when the downlink optical transmitter is turned off.

We measure the BER performances when the OSRBNR equals to 23, 21, 18, and 16 dB, and the results are shown in Fig. 7. As shown in Fig. 7(a), a receiver sensitivity of -20.5 dBm at 1×10^{-9} can be achieved when the OSRBNR equals 23 dB and the central WS equals 0 nm; the receiver sensitivity will reach -25 dBm at 1×10^{-9} if the central WS increases to 0.08 nm. There is just a slight deterioration of the receiver sensitivity when the OSRBNR drops to 21 dB as shown in Fig. 7(b). Values of -19.5 dBm at 1×10^{-9} and -24.5 dBm at 1×10^{-9} can be achieved when the central WS equals 0 and 0.8 nm, respectively. If the OSRBNR drops to 18 dB, the receiver sensitivity will further deteriorate. As shown in Fig. 7(c), the BER is worse than 1×10^{-9} even the optical signal power at the receiver is increased to the maximum that can be achieved. As a result, only -22.5 dBm at 1×10^{-4} and -27 dBm at 1×10^{-4} are achieved when the central WS equals 0 and 0.08 nm, respectively. Figure 7(d) shows that receiver sensitivity is further reduced when the OSRBNR drops to 16 dB, which is the minimum in our work. Values of -20.5 dBm at 1×10^{-4} and -25 dBm at 1×10^{-4} are achieved when the central WS equals 0 and 0.08 nm, respectively.

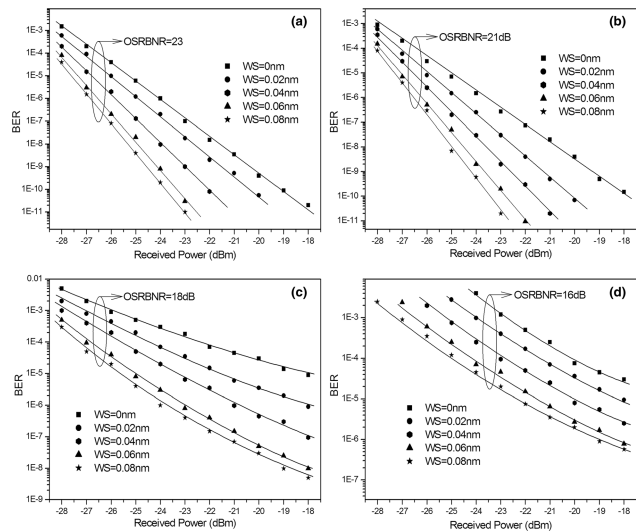

Fig. 7. BERs when the OSRBNR is the following; (a) 23 and (b) 21, (c) 18, (d) 16 dB.

Therefore, the receiver sensitivity will be seriously affected by the OSRBNR; the larger the OSRBNR, the better the receiver sensitivity. In order to obtain a large OSRBNR at the downlink receiver when the downstream optical power remains constant, the upstream optical power into the fiber should be as low as possible under the condition that the upstream optical power budget is met. Considering the correct transmission can be achieved with a forward-error correction (FEC) code regardless of how much the OSRBNR and central WS were, the channel-reuse DWDM-PON scheme is an effective solution to improve the system capacity with a high spectral efficiency.

In conclusion, we propose and investigate a tunable, laser-based, channel-reuse, bidirectional, 10 Gb/s/ λ , long-reach DWDM-PON scheme. An optical beat-noise-based automatic wavelength control method is also proposed to manage the wavelength of a tunable laser in a colorless ONU. A channel-reuse, bidirectional, 400 Gb/s capacity, 55 km, reach DWDM-PON system is demonstrated. The measurement results show the impact of the Rayleigh backscattering noise will decrease when the central WS and the OSRBNR increase. Using a 1×10^{-9} uniform BER standard, there is a maximal 5 dB performance improvement when the central WS increases from 0 to 0.08 nm. No matter how much the central WS and the OSRBNR were, an effective transmission implementation can be achieved in accordance with FEC codes in our work.

This work was supported by National Natural Science Foundation of China (No. 61302079), the National "863" Program of China (No. 2011AA01A104), and the Fund of State Key Laboratory of Information Photonics and Optical Communications (Beijing University of Posts and Telecommunications), China.

References

1. E. Wong, *IEEE J. Lightwave Technol.* **30**, 597 (2012).
2. D. Breuer, F. Geilhardt, R. Hülsermann, M. Kind, C. Lange, T. Monath, and E. Weis, *IEEE Commun. Mag.* **49**, S16 (2011).
3. F. J. Effenberger and J.-I. Kani, *IEEE J. Sel. Areas Commun.* **28**, 773 (2010).
4. K. Prince, T. B. Gibbon, R. Rodes, E. Hviid, C. I. Mikkelsen, C. Neumeyr, M. Ortsiefer, E. Rönneberg, J. Rosskopf, P. Ohlén, E. I. De Betou, B. Stoltz, E. Goobar, J. Olsson, R. Fletcher, C. Abbott, M. Rask, N. Plappert, G. Vollrath, and I. T. Monroy, *IEEE J. Lightwave Technol.* **30**, 1444 (2012).
5. J.-Y. Kim, S.-H. Yoo, S.-R. Moon, D. C. Kim, and C.-H. Lee, in *Proceedings of OFC 2013 OW4D.4* (2013).
6. L. Tawade, *Microwave Opt. Technol. Lett.* **55**, 1426 (2013).
7. H. He, J. Li, M. Bi, and W. Hu, *Chin. Opt. Lett.* **12**, 040603 (2014).
8. P. Chanclou, A. Cui, F. Geilhardt, H. Nakamura, and D. Nessel, *IEEE Network* **26**, 8 (2012).
9. D. Lavery, M. Ionescu, S. Makovejs, E. Torrenco, and S. J. Savory, *Opt. Express* **18**, 25855 (2010).
10. P. D. Townsend, G. Talli, C. W. Chow, E. M. MacHale, C. Antony, R. Davey, T. de Ridder, X. Z. Qiu, P. Ossieur, H. G. Krimmel, D. W. Smith, I. Lealman, A. Poustie, S. Randel, and H. Rohde, in *Proceedings of IEEE LEOS Annual Meeting ThW1* (2007).
11. G. Talli and P. D. Townsend, *IEEE J. Lightwave Technol.* **24**, 2827 (2006).
12. G. Talli, C. W. Chow, E. K. MacHale, and P. D. Townsend, *J. Opt. Netw.* **6**, 765 (2007).
13. Q. Guo, A. V. Tran, and C. J. Chae, *IEEE Photon. Technol. Lett.* **23**, 1442 (2011).
14. T. Su, M. Zhang, X. Chen, Z. Zhang, M. Liu, L. Liu, and S. Huang, *Opt. Laser Technol.* **51**, 90 (2013).
15. J. Zhang, J. Yu, F. Li, N. Chi, Z. Dong, and X. Li, *Opt. Express* **21**, 18842 (2013).
16. S.-H. Cho, H. H. Lee, J. H. Lee, J. H. Lee, S. Myung II, and S. S. Lee, *Opt. Fiber Technol.* **18**, 523 (2012).
17. H.-S. Kim, D. C. Kim, K.-S. Kim, B.-S. Choi, and O.-K. Kwon, *Opt. Express* **18**, 23324 (2010).
18. L. Liu, M. Zhang, M. Liu, and X. Zhang, *Chin. Opt. Lett.* **10**, 070608 (2012).
19. C. W. Chow, G. Talli, A. D. Ellis, and P. D. Townsend, *Opt. Express* **16**, 1860 (2008).
20. G. Talli, C. W. Chow, and P. D. Townsend, *IEEE J. Lightwave Technol.* **26**, 3190 (2008).
21. C. W. Chow and C. H. Yeh, *Opt. Express* **19**, 4970 (2011).
22. H. Feng, S. Xiao, L. Yi, Z. Zhou, J. Shi, and T. Qi, *Chin. Opt. Lett.* **11**, S20607 (2013).
23. J. H. Lee, K. O. Kim, S. I. Myoung, S. S. Lee, and Y. Seon, *Opt. Express* **19**, B522 (2011).
24. C. H. Yeh, C. W. Chow, C. H. Wang, F. Y. Shih, Y. F. Wu, and S. Chi, in *Proceedings of OECC 2009 ThLP47* (2009).
25. S.-R. Moon, H.-K. Lee, and C.-H. Lee, *J. Opt. Commun. Netw.* **5**, 190 (2013).