

# Frequency difference lock-in phenomenon's weakening by transverse magnetic field in Y-shaped cavity dual-frequency laser

Guangzong Xiao (肖光宗)\*, Bin Zhang (张斌), Zhiguo Wang (汪之国),  
Yangying Fu (傅杨颖), and Mengfan Gong (龚梦帆)

College of Optoelectronic Science and Engineering, National University of Defense Technology, Changsha 410073, China

\*Corresponding author: xiaoguangzong@nudt.edu.cn

Received July 3, 2015; accepted September 29, 2015; posted online October 16, 2015

We report experimental progress in weakening the frequency difference lock-in phenomenon in a Y-shaped cavity dual-frequency laser. A cube coil pair is chosen to provide a uniform magnetic field for tunability and uniformity of magnetic field strength. When the transverse magnetic field intensity is 9 mT, the frequency difference lock-in phenomenon is evidently weakened and the frequency difference can be continuously tuned in the range of 0.12 MHz to 1.15 GHz. Moreover, the relationship between the minimal frequency difference and magnetic field intensity are investigated and discussed. Then a Y-shaped cavity dual-frequency laser is expected to be utilized as an optimum light source for heterodyne interferometric sensing and precise laser measurement.

OCIS codes: 140.0140, 140.1340, 140.3460.

doi: 10.3788/COL201513.111405.

Orthogonally polarized dual-frequency lasers are widely applied in two-frequency interferometers, ellipsometers, displacement measurement, wave plate measurement, and other measuring systems<sup>[1-5]</sup>. However, for the He-Ne laser transitions there exists a lock-in frequency difference below which one of the polarized waves dies because of the strong competition among waves<sup>[6,7]</sup>.

Doyle and White pointed out that the mode competition could be overcome by the presence of a small magnetic field that is normal to the laser axis<sup>[8]</sup>. Gudelev and Yasinskiĭ experimentally investigated the lasing characteristics of the two-frequency He-Ne laser with an active medium located in a homogeneous transverse magnetic field<sup>[9]</sup>. They confirmed that the transverse magnetic field is an effective means of weakening the interaction of the orthogonally polarized waves.

Zhang *et al.* studied the Zeeman birefringence-type dual-frequency laser based on both the Zeeman effect and intracavity birefringence<sup>[10,11]</sup>. They applied a transverse magnetic field to decrease the mode competition and obtained the full frequency difference output from approximately 1 MHz to hundreds of MHz<sup>[12]</sup>.

In 2011, our group developed a novel dual-frequency laser based on the Y-shaped cavity; this laser was called a Y-shaped cavity dual-frequency laser, and we studied its characteristics<sup>[13-15]</sup>. Subsequently, the progress of research on its applications has been rapid. Micro-force measurements achieved a resolution of  $10^{-5}$  N using the Y-shaped cavity dual-frequency laser<sup>[16]</sup>. A novel approach for acceleration measurement has been demonstrated based on this type of laser. The investigation indicated that an acceleration measurement resolution of  $10^{-5}$ – $10^{-6}$  g in the range of  $\pm 5$  g can be expected<sup>[17]</sup>. A new displacement measurement configuration has been patented<sup>[18]</sup>.

Compared with other dual-frequency lasers with large frequency differences based on the birefringence effect, better frequency difference stability is expected in the developed laser because no birefringent element is in its cavity. Meanwhile, the frequency difference can be tuned to a certain value for adjusting to different applications for the abovementioned superiorities. The Y-shaped cavity dual-frequency laser is expected to bring about a revolution in precision measurement. However, the frequency difference lock-in phenomenon still exists, thereby affecting its performance in the measurement field.

In this Letter, we report the experimental progress in weakening the frequency difference lock-in phenomenon in a Y-shaped cavity dual-frequency laser. We developed a tunable and convenient transverse magnetic field setup and tested its magnetic field intensity distribution. Then, the basic principle of weakening the frequency difference lock-in phenomenon by a transverse magnetic field was analyzed. Moreover, we report the preliminary experimental results and discuss the minimal frequency difference variations with the transverse magnetic field intensity. Conclusions are given last.

Figure 1 shows the configuration of the weakening frequency difference lock-in phenomenon in a Y-shaped cavity dual-frequency laser and its accessorial experimental setup.

First, the two terms used in this Letter are defined as follows. P-light indicates that the electric field vector is perpendicular to the plane of incidence, whereas S-light indicates that the electric field vector is parallel to the plane of incidence. The Y-shaped cavity dual-frequency laser in Fig. 1 generates two orthogonal polarized lights with a frequency difference called P-light and S-light, respectively.

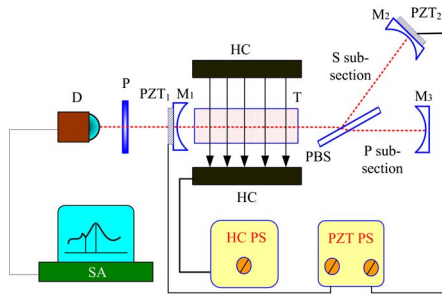

Fig. 1. Experiment setup of weakening frequency difference lock-in phenomenon in a Y-shaped cavity dual-frequency laser. PZT1, PZT2: piezoelectric transducer; P: polarization plate; D: photoelectric detector; SA: spectrum analyzer; HC: Helmholtz coil pair; HCPS: power supply for Helmholtz coil pair; PZTPS: power supply for PZT.

As shown in Fig. 1, the gain tube was filled with an He:Ne = 10:1 gas mixture at a pressure of 400 Pa to provide gain for both S-light and P-light, thereby resulting in a portion of the cavity (called “common section”) that they both pass through. The length of this portion is about 93 mm. Polarization beam splitter (PBS) separates the S-light and P-light, which then travel through the different subsections. M1, M2, and M3 are highly reflective mirrors. The part between PBS and M2 is called the “S subsection”, whereas that formed between PBS and M3 is called the “P subsection”. The common section joined with the S subsection and P subsection is called the “Y-shaped cavity,” given its shape. The total cavity length for P-light is 130 mm, which is equal to that for S-light. The reflectance of PBS for S-light and the transmittance for P-light are at 99.9% each at a specific angle of incidence because of the specially designed film structure and the deposition process of the optical coatings. This phenomenon leads to small transmission loss for S-light and reflection loss for P-light caused by PBS. Thus, two orthogonally polarized lights have a sufficient net gain to oscillate. P is the polarizing film that generates the beat frequency between the S-light and the P-light.

Early studies have indicated that the smallest magnetic field intensity needed to completely eliminate the frequency difference lock-in phenomenon and keep the frequency difference stable for orthogonally polarized dual-frequency He-Ne lasers is about 18 mT. Meanwhile, the region of the homogeneous magnetic field is sufficiently wide to cover the laser tube. A magnet is usually applied to produce a transverse magnetic field because of its simplicity and convenience. However, tuning its magnetic field intensity is difficult. The Helmholtz coil pair is a common method used to obtain a tunable homogeneous magnetic field. The conventional Helmholtz coil pair provides a uniform field at the center of the system. However, the ratio of the high-uniformity region and its volume is so small that a large Helmholtz coil pair is needed for the Y-shaped cavity dual-frequency laser, and such a size makes the device inconvenient to use.

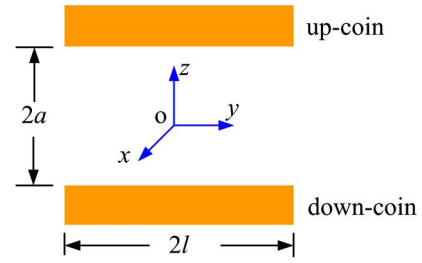

Fig. 2. Configuration of the cube coil pair.

Fortunately, the cube coil pair is a better choice because of its magnetic field strength uniformity and uniform field range. A self-built system comprising two identical square coils is used to provide a uniform magnetic field over a considerable part of the volume, as shown in Fig. 2. The magnetic field in the uniform field region is parallel to the face of the cube and perpendicular to the laser axis.

Two coils made of enamel wires that are wound on the square frameworks are connected in a series. The diameter of the enamel wire is about  $d = 1$  mm, and its maximum current density is  $i_{\max} = 3$  A/mm<sup>2</sup>. Thus, the maximum current  $I$  through the enamel wire is about  $I_{\max} = 2.35$  A. The number of turns in each coil is  $N = 600$ . To obtain a uniform magnetic field and a wider region of uniformity, the optimized relationship between the spacing  $2a$  between the loops and the length  $2l$  of the cube is as follows<sup>[9]</sup>:

$$a = 0.5445l. \quad (1)$$

Given that the length of the gain tube is about 93 mm, the length of the cube is set to  $2l = 110$  mm to achieve a sufficient uniform magnetic field range. The optimized spacing between loops is set as  $2a = 51$  mm, according to Eq. (1).

For convenience, a Cartesian coordinate system  $o-xyz$  is built, as shown in Fig. 2. The origin of the coordinate system  $o-xyz$  is set at the symmetric center of the cube coil pair and the  $y$  axis is parallel to the laser axis. The magnetic field intensity distribution of the cube coil pair is measured for various currents  $I$ . The experimental data in Fig. 3 are given only for the case in the plane  $zoy$  and along the  $y$  axis for  $I = 0.98, 1.49, 2.02,$  and  $2.48$  A, respectively.

The uniform field range is about 98 mm, with the magnetic field intensity of 4.2 mT, when the current  $I$  through the enamel wire is about  $I = 0.96$  A. However, the uniform field range became smaller than 93 mm when the current increased to 2 A.

According to the laser principle, the longitudinal mode spacing  $\Delta v_s$  and  $\Delta v_p$  can be calculated as follows:  $C/2L = 1.15$  GHz. The lasing bandwidth is about 1.5 GHz. Thus, three or four longitudinal modes may oscillate at the same time in the lasing bandwidth, as shown in Fig. 4. When the central frequency of two orthogonally polarized lights ( $v_s, v_p$ ) is close to the center of the gain profile the competition between them tends to weaken. Thus, the

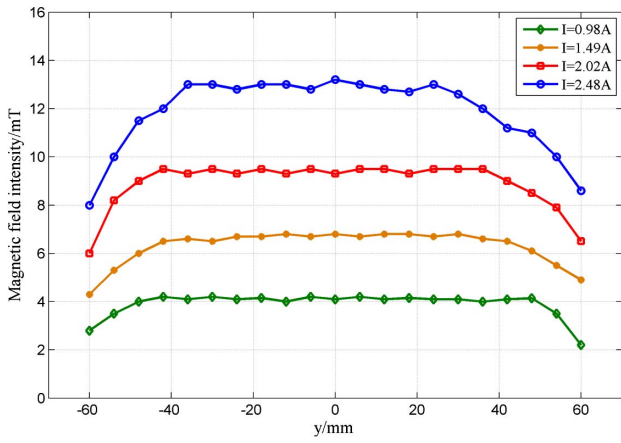

Fig. 3. Magnetic field intensity distribution along the  $y$  axis in the plane  $zoy$ , for a different current  $I$ .

voltage applied to PZT1 was changed to tune the frequency differences of  $\Delta v_1$  and  $\Delta v_2$ . Meanwhile, the powers of the two polarized lights are maintained to be equal by adjusting the voltage applied to PZT2.

The minimal frequency difference between two polarized lights can be observed using the frequency spectrum analyzer. Without a magnetic field the minimal frequency difference is about 12 MHz, which is called the lock-in frequency difference that stems from the strong competition between two polarized lights. After adjusting the current in the enamel wire of the loops, the magnetic field intensity near the discharge tube at different parameters changes. The minimal frequency difference varies with different magnetic field intensities, as shown in Fig. 5. The dashed line represents the lock-in frequency difference without a magnetic field, which is about 12 MHz.

When the magnetic field intensity increases the minimal frequency difference becomes smaller, demonstrating that the ability of weakening the frequency difference lock-in phenomenon is strengthened with a larger magnetic field intensity. Furthermore, the frequency difference lock-in phenomenon is eliminated when the magnetic field intensity reaches 9 mT. It is important to note here that both the lock-in frequency difference and the smallest magnetic field intensity to eliminate the frequency difference lock-in

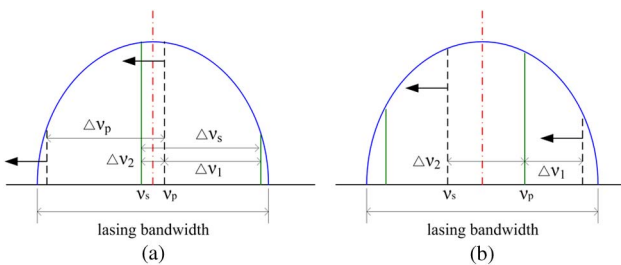

Fig. 4. Distribution of longitudinal modes along the frequency axis. Dashed lines represent P-light; solid lines represent S-light; arrows indicate the directions along which the longitudinal modes move while the voltage applied to PZT2 is increasing.

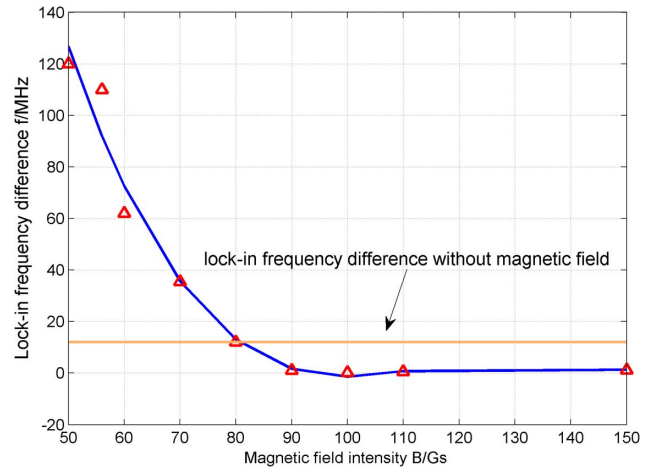

Fig. 5. Minimal frequency difference varying with different magnetic field intensity.  $\Delta$ : experimental data.

phenomenon are smaller than those of ordinary dual-frequency lasers. That is because the isotropic properties of intracavity components in a Y-shaped cavity dual-frequency laser are better than others.

However, the minimal frequency difference when the magnetic field intensity is smaller than 8 mT is larger than that without any magnetic field intensity. This result may be due to the transverse magnetic field splitting the gain profile of the laser into three parts,  $\pi$ ,  $\sigma^+$ , and  $\sigma^-$ , leading to the decrease in gain for the S-light and P-light. Thus, the competition between the S-light and P-light is more serious, although they do not enjoy the same gain media.

When the current through the enamel wire is set as  $I = 2$  A, the magnetic field intensity is about 9 mT, as shown in Fig. 2. The frequency difference is tuned with the voltage applied on PZT2 as shown in Fig. 6. The frequencies  $\Delta v_s$  and  $\Delta v_p$  are the beat frequencies produced by one polarized light longitudinal mode spacing. The frequencies  $\Delta v_1$  and  $\Delta v_2$  are the beat frequencies produced by two different polarized light longitudinal modes. The arrows represent the directions along which the longitudinal modes move while the voltage applied to the PZT2 increases. The P-light mode moves toward [Fig. 3(a)], and then away from the S-light mode [Fig. 3(b)], which leads to the knee point of the frequencies  $\Delta v_1$  and  $\Delta v_2$  in Fig. 6. The minimal frequency difference of 0.12 MHz is obtained when the voltage applied to PZT2 is about 10 V. Given that the minimal frequency difference is close to the frequency spectrum analyzer resolution of 0.3 MHz, the frequency difference lock-in phenomenon is effectively weakened in the Y-shaped cavity dual-frequency laser.

In our experiments, the frequency difference lock-in phenomenon is evidently weakened by a transverse magnetic field in the Y-shaped cavity dual-frequency laser. A cube coil pair is chosen to provide a uniform magnetic field because of its tunability and uniformity of magnetic field strength. The relationship between the minimal frequency difference and magnetic field intensity is investigated and analyzed by tuning the cube coil pair current. When the

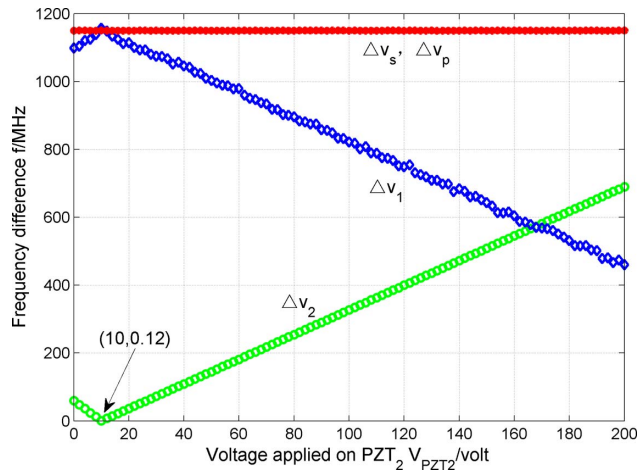

Fig. 6. Frequency differences tuning with the voltage applied on PZT2 when the magnetic field intensity is about 9 mT.

transverse magnetic field intensity is 9 mT, the lock-in effect is not found. Moreover, the minimal frequency difference reaches 0.12 MHz.

The frequency difference can be continuously tuned in the range of 0.12 MHz to 1.15 GHz. The Y-shaped cavity dual-frequency laser is expected to be an optimum light source for heterodyne interferometric sensing and precious laser measurement. Thus, the performances of micro-force measurement and acceleration measurement based on the Y-shaped cavity dual-frequency laser is enhanced. Furthermore, this laser also exhibits a capability of precise measurement of the refractive index and the density of a transparent medium by placing the sample in one sub-cavity (S subcavity or P subcavity) because of its special structure. Further investigations are being undertaken.

This work was supported by the National Natural Science Foundation of China under Grant No. 61308058.

## References

1. Z. Zhao, S. Zhang, P. Zhang, Z. Zeng, Y. Tan, and Y. Li, *Chin. Opt. Lett.* **10**, 0328011 (2012).
2. A. Takita, H. Ebara, and Y. Fujii, *Rev. Sci. Instrum.* **82**, 123111 (2011).
3. Z. Zhao, S. Zhang, Y. Tan, and Y. Li, *Chin. Opt. Lett.* **10**, 0214021 (2012).
4. J. Ding, Q. Feng, L. Zhang, and S. Zhang, *Appl. Opt.* **47**, 5631 (2008).
5. H. Wolfgang, N.-R. Stephan, and K. Michael, *Measurement* **28**, 277 (2000).
6. S. Zhang and T. Xu, *Prog. Nat. Sci.* **15**, 586 (2005).
7. S. Zhang and G. Liu, *Prog. Nat. Sci.* **15**, 865 (2005).
8. W. M. Doyle and M. B. White, *J. Opt. Soc. Am.* **55**, 1221 (1965).
9. V. G. Gudelev and V. M. Yasinskiĭ, *Sov. J. Quantum Electron.* **12**, 904 (1982).
10. Y.-Y. Jin, S. Zhang, Y. Li, J. Guo, and J. Li, *Chin. Phys. Lett.* **18**, 533 (2001).
11. X. Yan, S. Zhang, Y. Li, and Z. Jun, *Chin. Phys. Lett.* **20**, 230 (2003).
12. Y. Zhang, Y. Li, and S. Zhang, *J. Tsinghua Univ. (Sci. Technol.)* **47**, 1969 (2007).
13. G. Xiao, X. Long, and B. Zhang, *Chin. J. Lasers* **38**, 03020161 (2011).
14. G. Xiao, X. Long, and B. Zhang, *Opt. Precis. Eng.* **19**, 2581 (2011).
15. G. Xiao, X. Long, and B. Zhang, *Opt. Laser Technol.* **43**, 1314 (2011).
16. G. Xiao, X. Long, B. Zhang, and G. Li, *Chin. Opt. Lett.* **9**, 101201 (2011).
17. G. Xiao, X. Long, B. Zhang, and S. Jin, *Opt. Laser Technol.* **44**, 344 (2012).
18. X. Long, G. Xiao, and B. Zhang, "A displacement sensor based on Y-shaped cavity dual-frequency laser," Chinese Patent ZL201110341798.2 (2013).
19. R. Merritt, C. Purcell, and G. Stroink, *Rev. Sci. Instrum.* **54**, 879 (1983).