

# Uncertainty analysis of a pavement reflectance measurement system based on a gonio-photometer

Shenglong Fan (樊生龙), Muqing Liu (刘木清), and Haiping Shen (沈海平)\*

Department of Light Sources and Illuminating Engineering; Engineering Research Center of Advanced Lighting Technology, Ministry of Education, Fudan University, Shanghai 200043, China

\*Corresponding author: Shenhaiping@fudan.edu.cn

Received January 2, 2014; accepted March 20, 2014; posted online April 30, 2014

A pavement reflectance measurement system is established based on a gonio-photometer existing by changing a bracket to carry the road sample and luminance meter, adding a collimated light source to provide incident light. This automated system could finish the reflection measurement of a road sample in 4 h. An uncertainty budget of this measurement system is made and the combined standard uncertainty of  $Q_0$  is 5.26%.

OCIS codes: 120.5700, 220.4830.

doi: 10.3788/COL201412.051201.

It is essential and necessary to acquire the road reflectance characteristics before designing a high quality lighting installation<sup>[1]</sup>. The reflectance characteristics of the pavement have been measured by a lot of scientists since mid-1960s<sup>[2-6]</sup> and expressed as a table of reduced luminance coefficients called the r-table. Figure 1 shows one standard r-table, C2, which is recommended by CIE (International Commission on Illumination).

Generally, measurement is taken under 1 degree observation angle which results from the 1.5-m height of a driver's eyes looking at a point 86 m ahead from the driver's position. Bidirectional Reflectance Distribution Function (BRDF), which determines the distribution of reflected light under an illumination, can be used to describe the measured pavement reflection characteristics as<sup>[7]</sup>

$$q(\beta, \gamma) = \frac{L_p(\beta, \gamma)}{E_H}, \quad (1)$$

where  $\beta$  is the angle between vertical plane of incidence and vertical plane of observation, and  $\gamma$  is the angle of incidence from the downward vertical. Point P is the test point and  $L_p$  is the luminance of the point which can be measured by a luminance meter.  $E_H$  is the horizontal illuminance at point P.

According to CIE report 66-1984, road surfaces can be characterized by just two parameters, known as  $S_1$  and  $Q_0$ <sup>[8]</sup>.  $S_1$  is specular factor which is the relative strength of reflection at low incident angles compared to that at high incident angles.  $Q_0$  is the average luminance coefficient which is calculated as the integral of the product of the luminance coefficient  $q(\beta, \gamma)$  and the solid angle represented by  $q$  divided by the solid angle of all of the measurements as<sup>[2,9]</sup>

$$Q_0 = \frac{\int q(\beta, \gamma) d\Omega}{\int d\Omega}, \quad (2)$$

where  $\Omega$  is the solid angle of the integration area defined by CIE document 30.2. The integration limits for the  $Q_0$  calculation are  $\beta=0^\circ$  to  $180^\circ$  and  $\tan(\gamma)=-4$  to  $12$ .

Substitute Eq. (1) into Eq. (2),

$$Q_0 = \frac{\int \frac{L_p(\beta, \gamma)}{E_H} d\Omega}{\int d\Omega}. \quad (3)$$

However,  $Q_0$  is calculated in practice by

$$Q_0 = \frac{\sum_{\beta=0, \tan \gamma=0}^{\beta=180, \tan \gamma=12} \frac{L_p(\beta, \gamma)}{E_H} \cdot \Omega_{\beta, \gamma}}{\sum_{\beta=0, \tan \gamma=0}^{\beta=180, \tan \gamma=12} \Omega_{\beta, \gamma}} = \frac{\sum_{\beta=0, \tan \gamma=0}^{\beta=180, \tan \gamma=12} L_p(\beta, \gamma) \cdot \Omega_{\beta, \gamma}}{E_H \cdot \Omega_0}. \quad (4)$$

The integration boundaries are indicated in Figure 1.

Road surface reflectance measurement includes in-situ measurement and in-lab measurement. Compared with in-situ measurement, test in laboratory costs more time but can acquire more accurate data. By adding a collimated light source and changing the bracket, a gonio-photometer can be used to measure pavement reflectance in laboratory since  $q(\beta, \gamma)$  only has relationship with two angles.

This letter presents a brief description of the measurement system which is built up based on a gonio-photometer existing in Fudan University. The factors

tgγ	β°																			
	0	2	5	10	15	20	25	30	35	40	45	60	75	90	105	120	135	150	165	180
0	329	329	329	329	329	329	329	329	329	329	329	329	329	329	329	329	329	329	329	329
0.25	362	358	371	364	371	369	362	357	351	349	348	340	328	312	299	294	298	288	292	281
0.5	379	368	375	373	367	359	350	340	328	317	306	280	266	249	237	231	231	227	235	
0.75	380	375	378	365	351	334	315	295	275	256	239	218	198	178	175	176	176	169	175	176
1	372	375	372	354	315	277	243	221	205	192	181	152	134	130	125	124	125	129	128	128
1.25	375	373	352	318	265	221	189	166	150	136	125	107	91	93	91	91	88	94	97	97
1.5	354	352	338	271	213	170	140	121	109	97	87	76	67	65	66	66	67	68	71	71
1.75	333	327	302	222	166	128	104	90	75	68	63	53	51	49	49	47	52	51	53	54
2	318	310	266	180	121	90	75	62	54	50	48	40	40	38	38	38	41	41	43	45
2.5	268	262	205	119	72	50	41	36	33	29	26	25	23	24	25	24	26	27	29	28
3	227	217	147	74	42	29	25	23	21	19	18	16	16	17	18	17	19	21	21	23
3.5	194	168	108	47	30	22	17	14	13	12	12	11	10	11	12	13	15	14	15	14
4	168	136	76	34	19	14	13	11	10	10	10	8	8	9	10	9	11	12	11	13
4.5	141	111	54	21	14	11	9	8	8	8	8	7	7	8	8	8	8	8	10	11
5	126	90	43	17	10	8	8	7	6	6	7	6	6	7	6	6	7	8	8	9
5.5	107	79	32	12	8	7	7	7	6	5										
6	94	65	26	10	7	6	6	6	5											
6.5	86	56	21	8	7	6	5	5												
7	78	50	17	7	5	5	5													
7.5	70	41	14	7	4	3	4													
8	63	37	11	5	4	4	4													
8.5	60	37	10	5	4	4	4													
9	56	32	9	5	4	3														
9.5	53	28	9	4	4	4														
10	52	27	7	5	4	3														
10.5	45	23	7	4	3	3														
11	43	22	7	3	3	3														
11.5	44	22	7	3	3	3														
12	42	20	7	4	3															

Table C2  $Q_d/Q_0 = 0.054/0.070$   $S_1 = 0.97$

Fig. 1. CIE r-table C2

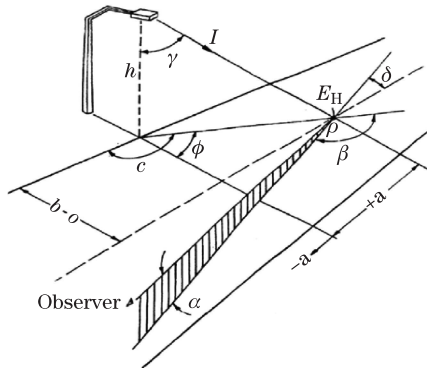

Fig. 2. Definition of pavement surface reflection.

which influence the measurement of  $Q_0$  is talked and an uncertainty budget is given. Finally, a combined standard uncertainty of 5.26% is obtained.

This measurement system is established based on a gonio-photometer by changing a bracket which can hold the road sample and an imaging luminance meter, adding a collimated light source to provide incident light. The gonio-photometer's arms can rotate automatically and their angle resolutions are all under  $0.01^\circ$ .

The detection system is made up of an imaging luminance meter (CX-2A, Ever fine photo-e-info co. ltd) and a reflective mirror (mirror 3). Imaging luminance meter is held by the bracket with 1 degree observation angle. The light source system comprises a halogen lamp and two reflective mirrors (mirror 1 and 2). The halogen lamp used in this system is a 100-W quartz-tungsten-halogen lamp, which is collimated by a reflector and operated at a color temperature of 3000 K. The light beam is incident directly to mirror 1 and then reflected to mirror 2 and then to the sample which is placed on the bracket. The reflected light from the sample is incident to mirror 3 and then the luminance meter can detect the reflected light from mirror 3.

During the measurement, gonio-photometer's arms rotates the luminance meter in  $\beta$  plane from 0 to 180 degree and incident light in  $\gamma$  plane with the range of  $[0^\circ, 85.24^\circ]$ . After gonio-photometer rotates to one measurement point, the detector records the luminance data and it can be saved automatically. The whole measurement procedure can be finished in 4 h.

The pavement reflectance,  $Q_0$ , is a function that relates to the illuminance falling on it from a given direction to its contribution to the luminance that is reflected at 1 degree observation angle. Besides, lamp drift should be considered. Therefore, it can be expressed by

$$Q_0 = f(L, E, \gamma, \alpha, \varphi), \quad (5)$$

where  $L$  represents luminance and  $E$  is illuminance,  $\gamma$  and  $\alpha$  represent incident angle and observation angle, respectively.  $\varphi$  represents lamp drift. According to the standard uncertainty assessment method recommended in GUM (Guide to the Expression of Uncertainty in Measurement)<sup>[10]</sup>, the uncertainty of  $Q_0$  is given by

$$u^2(Q_0) = \left| \frac{\partial f}{\partial L} \right|^2 u^2(L) + \left| \frac{\partial f}{\partial E} \right|^2 u^2(E) + \left| \frac{\partial f}{\partial \gamma} \right|^2 u^2(\gamma)$$

$$\begin{aligned} & + \left| \frac{\partial f}{\partial \alpha} \right|^2 u^2(\alpha) + \left| \frac{\partial f}{\partial \varphi} \right|^2 u^2(\varphi) \\ & = |c_1|^2 u^2(L) + |c_2|^2 u^2(E) + |c_3|^2 u^2(\gamma) \\ & + |c_4|^2 u^2(\alpha) + |c_5|^2 u^2(\varphi), \end{aligned} \quad (6)$$

where  $u(L)$  and  $u(E)$  represent the uncertainty component associated with the luminance and illuminance measurement, respectively;  $u(\gamma)$  is the uncertainty associated with incident angle;  $u(\alpha)$  is the uncertainty associated with observation angle.  $u(\varphi)$  is the uncertainty component caused by light source drift.  $c_i$  is sensitivity coefficient of each uncertainty component.

Luminance measurement uncertainty has three components: repeatability, linearity, and position uncertainty.  $u(L)$  can be calculated as

$$u^2(L) = u^2(L_r) + u^2(L_l) + u^2(L_p), \quad (7)$$

where  $u(L_r)$  represents the repeatability of the luminance meter. It is evaluated from the standard deviation of the readings of luminance meter under same luminance condition. We got three readings and the relative standard uncertainty is less than 0.04%.  $u(L_l)$  is the uncertainty of linearity of the luminance meter. The linearity of Luminance meter's CCD, as well as its amplifiers, is estimated by comparing its reading with those of the reference illuminance meter<sup>[11]</sup>.  $u(L_l)$  is less than 1% as luminance varies from 0.01 to 10 cd/m<sup>2</sup>.  $u(L_p)$  is the position uncertainty in luminance measurement which caused by angular uncertainty of bracket.  $u(L_p)$  is equal to 2% in the worst condition. Therefore,  $u^2(L)$  is 2.24%.

The sensitivity coefficient of  $u_L$  can be calculated by

$$c_1 = \frac{\partial f}{\partial L} \approx \frac{\Delta Q_0}{\Delta L}. \quad (8)$$

Assuming that the luminance of 580 tested points changes 1%, then  $\Delta Q_0$  is equal to  $2.87 \times 10^{-4}$  according to Eq. (9). Therefore,  $C_1$  is  $2.87 \times 10^{-4} / \%$ .

$$\begin{aligned} \Delta Q_0 = Q_0 - Q'_0 & = \frac{\sum_{\beta=0, \tan \gamma=0}^{\beta=180, \tan \gamma=12} L_p(\beta, \gamma) \cdot \Omega_{\beta, \gamma}}{E_H \cdot \Omega_0} \\ & - \frac{\sum_{\beta=0, \tan \gamma=0}^{\beta=180, \tan \gamma=12} L'_p(\beta, \gamma) \cdot \Omega_{\beta, \gamma}}{E_H \cdot \Omega_0}. \end{aligned} \quad (9)$$

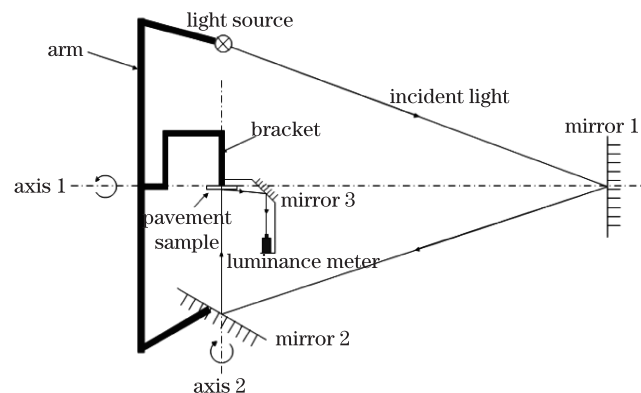

Fig. 3. Schematic of the experimental setup for the road surface reflectance measurement system.

Illuminance measurement uncertainty is made up of two components: repeatability and position uncertainty. The linearity uncertainty of illuminance meter can be neglected, therefore,  $u(E)$  is given by

$$u^2(E) = u^2(E_r) + u^2(E_p), \quad (10)$$

where  $u(E_r)$  represents the repeatability of the illuminance meter. According to the method used in  $u(L_r)$  evaluation,  $u(E_r)$  is less than 0.01%.  $u(E_p)$  is the relative standard uncertainty in illuminance measurement caused by position uncertainty. Its value is evaluated as less than 0.15%. Then, uncertainty in illuminance measurement is calculated equal to 0.15%.

The sensitivity coefficient of  $u(E)$  is calculated assuming that the illuminance on the sample changes 1 percent. Therefore,  $\Delta Q_0$  can be calculated by

$$\Delta Q_0 = Q_0 - Q'_0 = \frac{\sum_{\beta=0, \tan \gamma=0}^{\beta=180, \tan \gamma=12} L_p(\beta, \gamma) \cdot \Omega_{\beta, \gamma}}{E_H \cdot \Omega_0} - \frac{-\sum_{\beta=0, \tan \gamma=0}^{\beta=180, \tan \gamma=12} L_p(\beta, \gamma) \cdot \Omega_{\beta, \gamma}}{E'_H \cdot \Omega_0}. \quad (11)$$

Then,  $c_2$  can be obtained to be equal to  $2.869 \times 10^{-4} / \%$  by Eq. (4).

$$c_2 \approx \frac{\Delta Q_0}{\Delta E} = \frac{\Delta Q_0}{1\%}. \quad (12)$$

The standard uncertainty of incident angle,  $u(\gamma)$ , is evaluated equal to  $0.1^\circ$ .

The sensitivity coefficient of incident angle is given by

$$c_3 \approx \frac{\Delta Q_0}{\Delta \gamma} = \frac{\Delta Q_0}{0.1\%}. \quad (13)$$

Assuming incident angle changes 0.1 degree, the luminance of tested point,  $L'_p(\beta, \gamma')$ , can be obtained by linear interpolation. Then  $\Delta Q_0$  can be calculated as

$$\Delta Q_0 = Q_0 - Q'_0 = \frac{\sum_{\beta=0, \tan \gamma=0}^{\beta=180, \tan \gamma=12} L_p(\beta, \gamma) \cdot \Omega_{\beta, \gamma}}{E_H \cdot \Omega_0} - \frac{-\sum_{\beta=0, \tan \gamma=0}^{\beta=180, \tan \gamma=12} L_p(\beta, \gamma) \cdot \Omega_{\beta, \gamma}}{E'_H \cdot \Omega_0}. \quad (14)$$

Substitute Eq. (14) into Eq. (13), the sensitivity coefficient of  $3.815 \times 10^{-5} / ^\circ$  can be easily obtained.

The standard uncertainty of observation angle,  $u(\alpha)$ , is given by the positioning of the luminance meter and evaluated as  $0.1^\circ$ .

To calculate the sensitivity coefficient of  $u(\alpha)$ , we measured same sample three times in different observation angles ( $0.5^\circ$ ,  $1^\circ$ , and  $1.5^\circ$ ) and  $c_4$  is calculated equal to  $1.361 \times 10^{-2} / ^\circ$  by

$$c_4 \approx \frac{\Delta Q_0}{\Delta \alpha} = \frac{\Delta Q_0}{0.5\%}. \quad (15)$$

Lamp drift has to be considered because illuminance is measured at the beginning while luminance is measured during the whole test. Considering the vibration of power source, the relative standard uncertainty of light source drift is evaluated as less than 1%.

It is assumed that the luminance declines 1% when measurement is finished and that the luminance is falling uniformly during the test. Thus, the luminance of tested point  $L''_p(\beta_i, \gamma_j)$  can be calculated by

$$L''_p(\beta_i, \gamma_j) = L_p(\beta_i, \gamma_j) / \left\{ 1 - \frac{1\% \times [20 \times (j-1) + i]}{579} \right\}, \quad (16)$$

where  $i$  &  $j$  represent the number of  $\beta$  &  $\gamma$ , respectively. Then,  $\Delta Q_0$  can be obtained by

$$\Delta Q_0 = \frac{Q_0 - Q'_0}{Q_0} = \frac{\sum_{\beta=0, \tan \gamma=0}^{\beta=180, \tan \gamma=12} L_p(\beta, \gamma) \cdot \Omega_{\beta, \gamma}}{\sum_{\beta=0, \tan \gamma=0}^{\beta=180, \tan \gamma=12} L_p(\beta, \gamma) \cdot \Omega_{\beta, \gamma}} - \frac{-\sum_{\beta=0, \tan \gamma=0}^{\beta=180, \tan \gamma=12} L''_p(\beta, \gamma) \cdot \Omega_{\beta, \gamma}}{\sum_{\beta=0, \tan \gamma=0}^{\beta=180, \tan \gamma=12} L_p(\beta, \gamma) \cdot \Omega_{\beta, \gamma}}. \quad (17)$$

Subsequently, the sensitivity coefficient of lamp drift is equal to  $-1.066 \times 10^{-2} / \%$  calculated by

$$c_5 \approx \frac{\Delta Q_0}{\Delta \varphi} = \frac{\Delta Q_0}{1\%}. \quad (18)$$

Sample position uncertainty needn't to be considered in this measurement system, because the field of view of the luminance meter is large enough to take a photo of the road sample, misalignment in the  $x$ ,  $y$  and  $z$  directions does not influence  $Q_0$  values any more. Besides, environment temperature is controlled by an air conditioner, thus the uncertainty of temperature also can be neglected.

Finally, substitute all the uncertainty components and sensitivity coefficients into Eq. (6), we can conclude that the measurement uncertainty of  $Q_0$  is  $1.51 \times 10^{-3}$ . A typical sample's  $Q_0$  is 0.287, therefore the relative standard uncertainty of the system is about 5.26% and the relative expanded uncertainty is 10.5% ( $k=2$ ). All the uncertainty components which were calculated above are listed in Table 1. From Table 1 we can find that the observation

**Table 1. Uncertainty Budget of Pavement Reflectance Measurement**

Source of Uncertainty	Standard Uncertainty	Sensitivity Coefficient	Uncertainty in $Q_0$
Luminance Measurement	2.24%	$2.869 \times 10^{-4} / \%$	$6.42 \times 10^{-4}$
Illuminance Measurement	0.1503%	$2.869 \times 10^{-4} / \%$	$4.31 \times 10^{-5}$
Incident Angle	$0.1^\circ$	$3.815 \times 10^{-5} / ^\circ$	$3.82 \times 10^{-6}$
Observation Angle	$0.1^\circ$	$1.361 \times 10^{-2} / ^\circ$	$1.36 \times 10^{-3}$
Light Source Drift	1%	$-1.066 \times 10^{-2} / \%$	$-1.07 \times 10^{-4}$
Combined Standard Uncertainty	$1.51 \times 10^{-3}$	Relative Standard Uncertainty	5.26%
Relative Expanded Uncertainty		10.5% ( $k=2$ )	

angle is the most sensitive uncertainty component and contributes most to the overall uncertainty. This is due to that the reflectance of the mirror is angle sensitive. In order to improve the system uncertainty, mirror 3 can be removed. However, the bracket for the luminance meter needs much larger space to obtain adequate observation distance. Then the whole experimental apparatus needs to be rebuilt.

In conclusion, a brief description of a road surface reflectance measurement system is presented in this letter. The system is developed based on a gonio-photometer by changing a bracket and adding a collimated light source. The measurement uncertainty of this system is analyzed using standard GUM method. A relative standard uncertainty of 5.26% of the measurement system is obtained.

## References

1. R.E. Stark, *Lighting Design and Application* (1986).
2. R. B. Gibbons and W. K. Adrian, *J. Illuminating Engineering Society* **26**, 139 (1997).
3. P. Fiorentin, P. Iacomussi, and G. Rossi, *IMTC 2004 - Instrumentation and Measurement Technology Conference Como, Italy* (2004).
4. P. Fiorentin and A. Scroccaro, *IEEE Trans. Instrum. Meas.* **57**, 2522 (2008).
5. R-Tech-Schreder and University of Liege, "Characterization of road surface using a mobile gonio-reflectometer," *CIE News* (2006).
6. K. Jiang, K. Yu, and Y. C. Zhao, *Chin. Opt. Lett.* **10**, (2012).
7. L. Li, Z. Wang, F. Pei, and X. Wang, *Chin. Opt. Lett.* **11**, 021102 (2013).
8. CIE 66-1984, "Road surfaces and Lighting (Joint CIE/PIARC publication)".
9. CIE 141-2001, "Road surface and road marking reflection characteristics".
10. International Organization for Standardization. "Guide to the expression of uncertainty in Measurement," the second edition (1995).
11. P. Fiorentin and A. Scroccaro, *IEEE Trans. Instrum. Meas.* **59**, 1375 (2010).