

Multi-wavelength generation by intra-cavity frequency doubling of PPKTP optical parametric oscillator

Bin Jiao (焦彬), Jinrong Tian (田金荣)*, Xinping Zhang (张新平),
Yanrong Song (宋晏蓉), and Li Wang (王丽)

*Institute of Information Photonics Technology and College of Applied Sciences,
Beijing University of Technology, Beijing 100124, China*

*Corresponding author: jrtian@bjut.edu.cn

Received January 30, 2013; accepted March 10, 2013; posted online July 17, 2013

A ring-cavity synchronously-pumped optical parametric oscillator (OPO) is investigated based on periodically poled KTi:OPO_4 (PPKTP). The wavelength of the signal wave covers from 1000 to 1500 nm, the output power is 32.3 mW, and idler wave spectrum range from 1800 to 2500 nm is detected. By inserting a BBO or BIBO crystal respectively, a stable and adjustable range from 450 to 650 nm light is obtained. Three to six wavelengths can be output simultaneously.

OCIS codes: 190.4410, 160.4330.

doi: 10.3788/COL201311.S21901.

Optical parametric oscillator (OPO), as efficient, tunable device for frequency conversion, has been investigated for years. Its spectral coverage extends from the ultraviolet to the infrared, and with its temporal coverage extending from the femtosecond pulse to the continuous wave^[1]. Such sources can generate coherent light with outstanding optical quality. Phase matching is important in optical parametric generation. In past years, birefringence phase matching (BPM) could be used to obtain phase matching. In 1962, the technique of quasi-phase matching (QPM) was proposed by Bloembergen, and in 1994, through the use of periodically poled nonlinear materials, QPM was brought into reality and had a deeply impact on nonlinear optics^[2]. At present, the nonlinear material periodically poled LiNbO_3 (PPLN) and periodically poled KTi:OPO_4 (PPKTP) has been the major roles. PPLN has a large nonlinear coefficient, so it has been widely used since its invention. Compared to PPLN, PPKTP has a lower nonlinear coefficient; however, PPKTP has a relatively lower polarization voltage and larger damage threshold. Furthermore PPKTP is not sensitive to the change of temperature under room temperatures, which makes it suitable for OPO with a high power^[3–10].

At present, OPO has been widely used in many fields, such as spectroscopy, medical diagnostics, physical, biophysical, biomolecules research, optical frequency metrology, optical communications etc. In many cases, a laser with single wavelength is not enough. Thus a multi-wavelength laser is necessary. In this paper, we apply intra-cavity frequency doubling technique into a synchronously-pumped OPO. Four to seven wavelengths can be output simultaneously. The spectral characteristics are detected in detail.

The OPO configuration is shown in Fig. 1. The pump source is a self-mode-locked Ti:sapphire laser with a pulse duration of 150 fs and repetition rate of 76 MHz. L is focusing lens with a focal length of 10 cm. M1, M2, M7, and M8 are concave mirrors, with a radius of curvature $R=100$ mm, and a PPKTP crystal is placed near the common focus of M1 and M2. M3–M6 are plane mir-

rors. All the reflective mirrors are chirped mirrors with high reflectivity from 1000- to 1500-nm coating. M3 and PPKTP are both mounted on translation stages for optimizing the laser operation. The length of cavity is about 394 cm according to the repetition rate of pump. By collimating the mirrors and fine tuning the cavity length, the parametric oscillation is obtained.

First of all, without BBO or BIBO crystal, fixing the pump wavelength on 800 nm and varying the pump power, the output power is measured. To filter pump light, a plane mirror with a high reflectivity from 700 to 900 nm is placed before the power meter. Figure 2 shows the result, which shows that the output power is generally proportional to the pump. The maximal

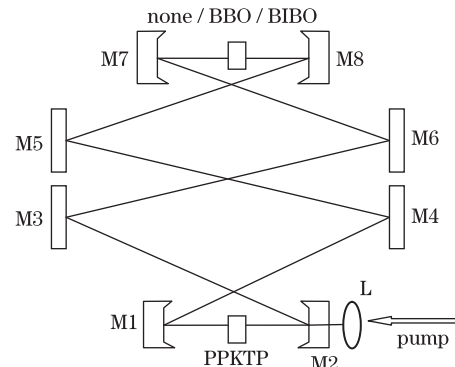

Fig. 1. Schematic of the OPO configuration.

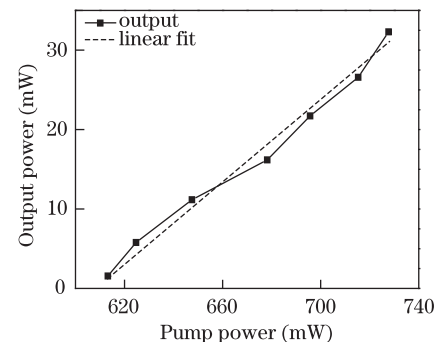

Fig. 2. Output power versus pump power.

output power is 32.3 mW at pump power of 727.7 mW. The corresponding slope efficiency is estimated to be about 27%, however, the pump threshold is relatively high for the introduction of a coupled cavity. The signal wave and idler wave's spectra are measured, as shown in Fig. 3. Figure 3(a) shows the spectra of signal waves, whose wavelength cover from 1000 to 1500 nm at near-infrared region, the corresponding idler waves' wavelengths covering from 1700 to 4000 nm from near-infrared to mid-infrared range. Figure 3(b) shows part of spectra of the idler waves. Due to the limitations of spectrometer, the idler waves' spectra range beyond 2500 nm cannot be displayed. It is noteworthy that signal waves can be tuned by cavity length tuning. In a specific range of cavity length, we can obtain a broad spectrum as shown in Fig. 4, from which the full-width at half-maximum (FWHM) of the spectrum can be deduced to be about 90 nm, which supports generation of a 30-fs pulse with a Gaussian approximation. However, though the spectrum is not regular, and the intra-cavity dispersion is not clear, the pulse duration entails further determination.

We further introduce a nonlinear crystal to get the second harmonic of the signal wave. The nonlinear crystal is located near the common focus of M7 and M8. In the experiment, three crystals are used in succession, including two BBO crystals and one BIBO crystal. The BBO crystals are cut for type-I phase matching with high transmission coating from 1100 to 1400 nm with a dimension of $4 \times 4 \times 2$ (mm), and the cut angle are $\theta=21.2^\circ$, $\varphi=0$ and $\theta=29.2^\circ$, $\varphi=0$ respectively. After fine tuning the cavity, the second harmonic of the signal wave is obtained.

Figure 5 shows the spectra of the second-harmonic generation (SHG) with BBO crystal with cut angle of $\theta=21.2^\circ$, $\varphi=0$. In Fig. 5, the wavelength near 800 nm is the pump, and the wavelength near 400 nm is the second

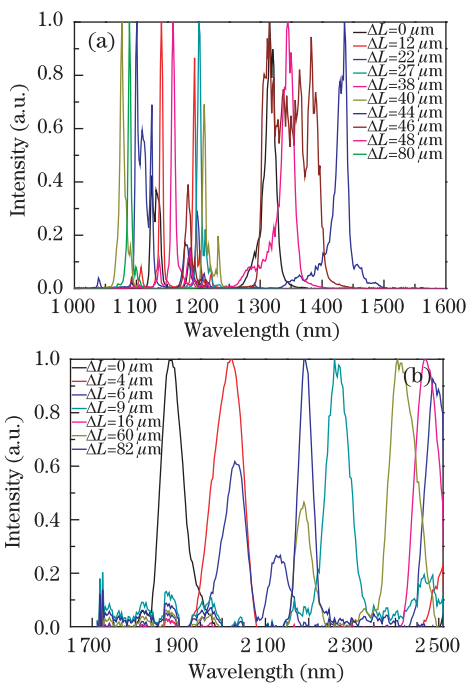

Fig. 3. (Color online) (a) Spectra of signal waves and (b) idler waves.

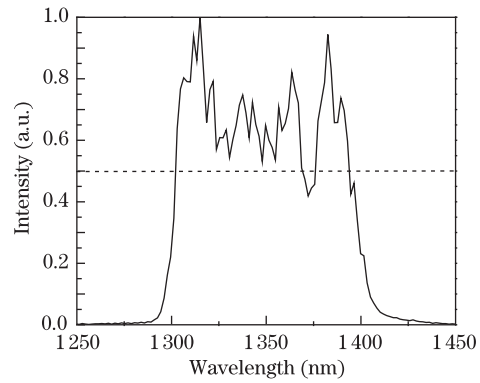

Fig. 4. A broad spectrum.

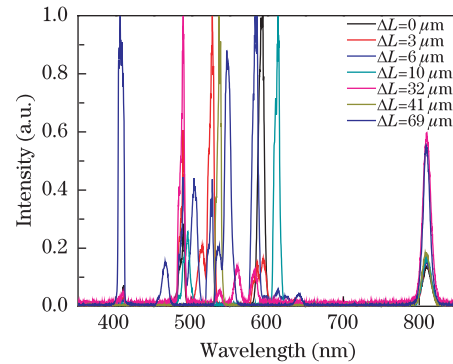

Fig. 5. (Color online) SHG spectra using BBO with a cut angle of $\theta=21.2^\circ$, $\varphi=0$.

harmonic of the pump. The SHG of signal wave can be tuned from 450 to 650 nm. However the wavelength of 450 nm is not the SHG of signal, instead, it is the sum frequency of pump wave and signal wave.

In Fig. 5, we also find quite a few spectra have two or more peaks. We consider it is due to the complex nonlinear process in the PPKTP crystal, which justifies more wavelengths' generation besides signal, idler and their SHG. In our experiment, the sum frequency of pump wave and signal wave, the sum frequency of pump wave and idler wavelength, even the third harmonic of the signal wave can be observed, which is due to the phase matching in a definite environment. So corresponding to a definite cavity length, three to six wavelengths will be generated simultaneously, in which four are controllable, and the other three appear randomly with environmental change. If the cavity length is tuned in more precisely, a smoother wavelength shift can be obtained.

Subsequently, we replace the BBO with another BBO with different cut angles, as shown in Fig. 6. Though the cut angle is different from the previous BBO crystal, the tuning range of SHG is very similar. However, the wavelength shift with cavity length tuning is not same. We think this is due to the different phase matching condition of two BBO crystals. Corresponding to the same cavity length mismatch, different wavelength in BBO crystal meets the phase matching, thus different SHG is generated. Furthermore, the tuning range of SHG is determined by the signal wave, which is the same to the BBO crystal, thus the tuning range of the SHG is almost the same.

Finally, we replace BBO with BIBO with a cut angle

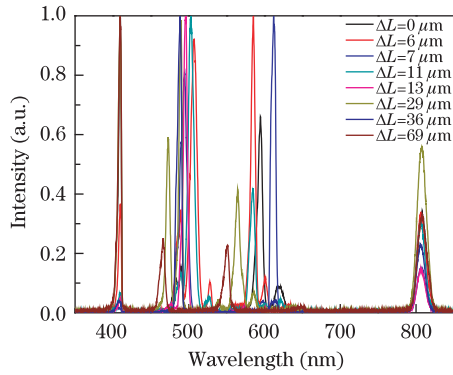

Fig. 6. SHG spectra using BBO with a cut angle of $\theta=29.2^\circ$, $\varphi=0$.

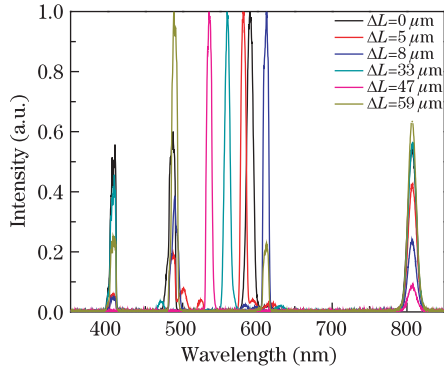

Fig. 7. SHG spectra using BIBO with a cut angle of $\theta=151.2^\circ$, $\varphi=90^\circ$.

of $\theta=151.2^\circ$, $\varphi=90^\circ$, and the SHG of signal waves are shown in Fig. 7. Its tuning range is similar to that using BBO crystal, and the tuning characteristic with cavity length mismatch is different from that using BBO crystals. We also think it is due to the different phase matching conditions between BBO and BIBO. Attributed to the different nonlinear efficiency between 1 000 and 1 500 nm, the output power of the visible light is different when using different crystal for SHG.

We also note that the SHG of signal wavelength only reaches about 650 nm, not near 750 nm although the signal wave covers from 1 000 to near 1 500 nm. We consider this is because the BBO/BIBO crystal, which is designed for the wavelength of near 1 200 nm, cannot satisfy the phase matching condition. If replace them with a crystal working in 1 400 nm, we believe the wavelength from 650 to 750 nm can also be output. Another factor accounts for the lack from 650 to 750 nm is that the signal wave

from near 1 300 to 1 500 nm is relative low compared with the wavelength of near 1 200 nm.

In conclusion, a multi-wavelength synchronously pumped OPO based on PPKTP is demonstrated. The OPO is in ring cavity arrangement and the maximal output power is 32.3 mW, at pump power of 727.7 mW. Three nonlinear crystals are used in succession for frequency doubling the signal wavelength. A femtosecond pulse whose spectrum extends from 450 to 650 nm (SHG of signal wave, visible), from 1 000 to 1 500 nm (signal wave, near infrared), and from 1 700 to 4 000 nm (idler wave, near infrared–mid infrared) is obtained. All the wavelengths can be accurately tuned by cavity length adjustment. Due to the nonlinear process in PPKTP or BBO/BIBO crystal, three to six wavelengths can be output simultaneously. We believe this multi-wavelength OPO system will benefit those spectroscopic applications where multi-wavelength light source is desired.

This work was supported by Beijing Municipal Natural Science Foundation (No. 1102005) Beijing Municipal Education Commission Project (No. KM201010005007), and National Nature Science Foundation (No. 61177047).

References

1. M. H. Dun and M. Ebrahimzadeh, *Science* **286**, 1513 (1999).
2. L. E. Myers, R. C. Eckardt, M. M. Fejer, R. L. Byer, W. R. Bosenberg, and J. W. Pierce, *J. Opt. Soc. Am. B* **12**, 2102 (1995).
3. L. E. Myers and W. R. Bosenberg, *IEEE J. Quantum Electron.* **33**, 1663 (1997).
4. H. Karlsson and F. Laurell, *Appl. Phys. Lett.* **71**, 3474 (1997).
5. J.-P. Fève., O. Pacaud, B. Boulanger, B. Ménaert, J. Hellström, V. Pasiskevicius, and F. Laurell, *Opt. Lett.* **26**, 1882 (2001).
6. R. C. Pooser and O. Pfister, *Opt. Lett.* **30**, 2635 (2005).
7. S. Ast, R. M. Nia, A. Schönbeck, N. Lastzka, J. Steinlechner, T. Eberle, M. Mehmet, S. Steinlechner, and R. Schnabel, *Opt. Lett.* **36**, 3467 (2011).
8. P. Groß, I. D. Lindsay, C. J. Lee, M. Nittmann, T. Bauer, J. Bartschke, U. Warring, A. Fischer, A. Kellerbauer, and K.-J. Boller, *Opt. Lett.* **35**, 820 (2010).
9. A. Esteban-Martin, O. Kokabee, and M. Ebrahim-Zadeh, *Opt. Lett.* **33**, 2650 (2008).
10. S. Chiow, T. Kovachy, J. M. Hogan, and M. A. Kasevich, *Opt. Lett.* **37**, 3861 (2012).