

Modulation-free laser frequency offset locking using buffer gas-induced resonance

Guoqing Yang (杨国卿)¹, Yunfei Xu (徐云飞)^{1*}, Qiang Lin (林强)^{1**}
and Han Zhang (张寒)²

¹*Institute of Optics, Department of Physics, Zhejiang University, Hangzhou 310027, China*

²*Service OPERA-photonique, Université libre de Bruxelles (U.L.B.), 50 Avenue F. D. Roosevelt,
CP 194/5, B-1050 Bruxelles, Belgium*

*Corresponding author: xuyf@zju.edu.cn; **corresponding author: qlin@zju.edu.cn

Received May 30, 2013; accepted September 4, 2013; posted online, 2013

We experimentally demonstrate a simple modulation-free scheme for offset locking the frequency of a laser using buffer gas-induced resonance. Our scheme excludes the limitation of low diffraction efficiency and laser input intensity when an acousto-optic modulator is applied to shift the laser frequency from the resonance. We show the stabilization of a strong 795-nm laser detuned up to 550 MHz from the ⁸⁷Rb 5S_{1/2}F=2→5P_{1/2} F'=2 transition. The locking range can be modified by controlling the buffer gas pressure. A laser line width of 2 MHz is achieved over 10 min.

OCIS codes: 020.3690, 140.2020, 140.3425, 270.1670, 300.6260, 300.6420.
doi: 10.3788/COL201311.100201.

Stable laser sources detuned from resonance have important applications for laser-atom interactions in the field of atomic and molecular physics^[1,2]. Raman lasers are detuned by hundreds of megahertz from resonance in atom interferometers^[3,4]. Pump lasers are commonly detuned several gigahertz from resonance in atomic filters^[5]. Nonlinear optical processes with polychromatic fields require lasers to be detuned from resonance^[6–8]. Laser fields must be sufficiently strong to enhance the interaction strength in these experiments.

Numerous methods for locking a laser source to an atomic transition have been proposed. An example of these methods is shifting the laser frequency from the resonance with an acousto-optical modulator (AOM)^[9] or an electro-optical modulator (EOM)^[10]. However, this method possesses two significant disadvantages, i.e., the low diffraction efficiency of an AOM in several hundreds of megahertz modulation frequency and the laser input intensity limitation. The crystal in the modulator may be easily damaged under high input laser. If the laser is modulated with an EOM, the lasers at different frequencies are combined by a common beam, which is an obstacle for applications.

Correspondingly, many offset locking methods have been developed to overcome this drawback. One way is based on the beating signal between two lasers^[11,12], with difficulty in phase detection and rapid proportional-integral-derivative processes. Another technique is cavity-assisted frequency locking. The laser frequency can be tuned by changing the cavity length^[13]. Lasers at different wavelengths could be synchronically locked with one cavity^[14]. Nevertheless, a stable cavity system with a precise cavity length is difficult to build. The third method is atomic spectroscopy. Offset locking with electromagnetically induced transparency (EIT) resonance^[15–17], electromagnetically induced absorption (EIA) resonance^[18], and Faraday effect^[19] has been experimentally demonstrated. The lock-in technology is always required to ob-

tain a zero crossing error signal, which may introduce additional modulation noise. Although the method with the Faraday effect does not need modulation, the slope is significantly flat, such that the fluctuation of the laser frequency is large compared with other methods and the frequency offset must not be less than 6 GHz^[19].

In this letter, we experimentally demonstrate a simple laser frequency offset locking scheme using buffer gas-induced resonance. The buffer gas-induced resonance has been reported and well studied^[20–22]. When a bichromatic field interacts with a three-level system in the presence of a buffer gas, the spectroscopy will be affected by the buffer gas. The main idea is that the buffer gas can prolong the ground state coherent lifetime and broaden the optical transition. As a result, the line shape is modulated by the buffer gas. The spectroscopy is a symmetric Lorentzian EIT peak when the one-photon detuning is zero, it becomes a symmetric Lorentzian EIA peak when the one-photon detuning is more than gigahertz, and it is shown as a zero crossing asymmetric resonance curve when the one-photon detuning is about several hundreds of megahertz, which could be applied as an error signal for frequency locking. We use the buffer gas-induced asymmetric resonance in this study to stabilize a laser without modulation, which is different from the scheme for laser frequency stabilization with EIT^[15–17]. In the scheme with EIT, the lights are considered resonance. The coupling light is locked with the saturated absorption spectroscopy (SAS) first. The probe light is then locked with modulated EIT signal to match with the atomic transition.

In our scheme shown in Fig. 1, both of the lights are off resonance. The laser that will be locked is the strong coupling light. The coupling light can be directly generated with an AOM when the detuning is at the range of several hundreds of megahertz. However, the diffraction efficiency of an AOM is usually very low for hundreds of megahertz.

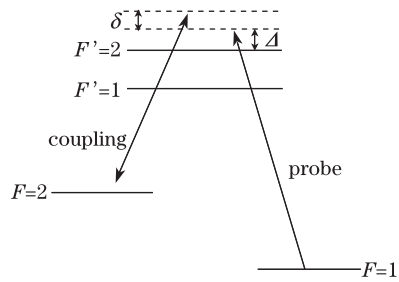

Fig. 1. Rubidium 87 energy levels. The strong coupling light drives the $5S_{1/2}F=2 \rightarrow 5P_{1/2}F'=2$ transition, whereas the weak probe light drives the $5S_{1/2}F=1 \rightarrow 5P_{1/2}F'=2$ transition. Δ represents single-photon detuning and δ is the two-photon detuning.

To save the strong coupling light power, the probe light is generated with an AOM. A laser is first locked to the $5S_{1/2}F=1 \rightarrow 5P_{1/2}F'=2$ transition whose frequency is shifted by an AOM. The diffracted light is used as the probe light. The modulation frequency of the AOM is the one-photon detuning, which decides the offset of the coupling light relative to the $5S_{1/2}F=2 \rightarrow 5P_{1/2}F'=2$ transition. A probe is usually very weak, and neither the conversion efficiency nor the input laser intensity limitation of the AOM is important.

The experimental setup is illustrated in Fig. 2. Laser 1 is a Toptica DL 100 laser with a wavelength of 795 nm and a maximum output power of 105 mW, which enters the rubidium vapor as coupling light. The laser power is changed by a half-wave plate and a polarizing beam splitter, and is weakly attenuated after passing through the vapor when the light is off resonance. Laser 2 is an Optoquantum ECL 2000 laser, which is locked to the $5S_{1/2}F=1 \rightarrow 5P_{1/2}F'=2$ transition with modulation-free polarization spectroscopy^[23–25]. The light from laser 2 is modulated by an AOM with a modulation frequency of 550 MHz and a conversion efficiency of $\sim 50\%$. The +1st-order diffracted light is applied as the probe light and detected by an optical detector.

In the experiment, the room temperature Rb vapor is filled with 10 torr He gas as buffer gas. The power of the coupling light is 80 mW, whereas that of the probe light is 100 μ W. The coupling light diameter is about 5 mm. The signals are monitored using a Tektronix oscilloscope. In Fig. 3(a), the lower black curve is the SAS (the experimental setup is not shown in Fig. 2). The upper red curve is the transmission signal of the probe light, which is a zero crossing curve, so that it is highly suitable for modulation-free laser frequency locking. Only one optical detector is used in our scheme, which is quite different from other modulation-free laser frequency locking technologies and simplifies the optical detection method. Moreover, we do not detect the coupling light directly. Therefore, the power of the strong coupling laser remains constant. Furthermore, the background of the buffer gas-induced resonance is a flat-straight line instead of the Doppler absorption profile. The Doppler background is usually observed in typical EIT experiments if the probe light is scanned while the coupling light is locked. For comparison, we also show the experimental results in the abovementioned situation. As shown in Fig. 3(c), the detuning of the coupling light was 0, 550, and 960 MHz. With the buffer gas, the

resonance changes from EIT to EIA by increasing the detuning of the probe light. Therefore, the buffer gas-induced resonance without a Doppler background is more beneficial for laser frequency locking. In most laser-atom interaction experiments, the line width is an important parameter. Figure 3(a) shows that the line width of the buffer gas-induced resonance is narrower than that of SAS. By zooming in its fine structure, we find that the line width is about 10 MHz, as shown in Fig. 3(b). Therefore, the locking laser frequency with the buffer gas-induced resonance can make the laser more stable.

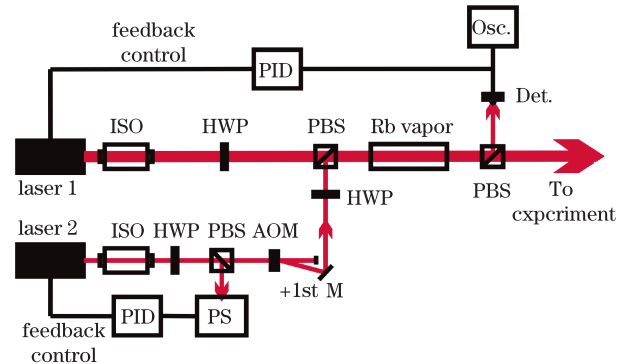

Fig. 2. Experimental setup for frequency offset locking using buffer gas-induced resonance. laser 1: for coupling light; laser 2: for probe light; ISO: optical isolator; HWP: half-wave plate; PBS: polarizing beam splitter; PS: polarization spectroscopy; AOM: acousto-optical modulator; PID: proportional-integral-derivative; +1st: positive first-order light; M: mirror; Det.: optical detector; Osc.: oscilloscope; Rb vapor: rubidium vapor.

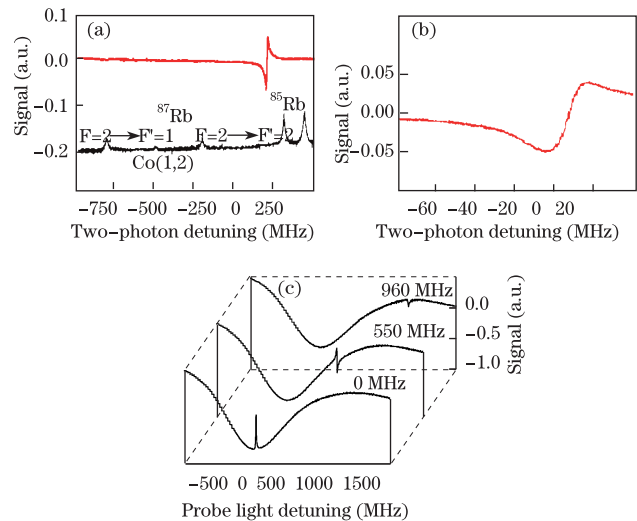

Fig. 3. (Colored online) Experimental results of spectroscopy. (a) and (b): spectrum of the frequency scanning of the coupling light while the probe light is locked. In (a), the upper red curve is the buffer gas-induced resonance; the lower black curve is the saturated absorption spectroscopy. $F=2 \rightarrow F'=1$ denotes $5S_{1/2}F=2 \rightarrow 5P_{1/2}F'=1$ transition and $F=2 \rightarrow F'=2$ denotes $5S_{1/2}F=2 \rightarrow 5P_{1/2}F'=2$ transition. Co(1, 2) is the crossover peak. In (b), the scanning range of the coupling light is reduced for measuring the line width of the buffer gas-induced resonance. (c): spectrum of the frequency scanning of the probe light while the coupling light is locked. The detuning of the coupling light are 0, 550, and 960 MHz.

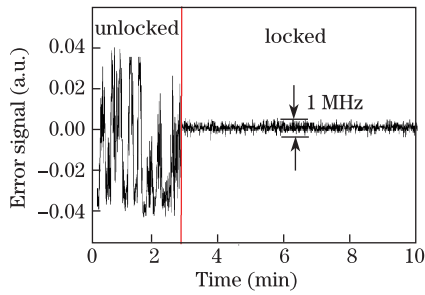

Fig. 4. Error signal before and after the frequency of the coupling light is locked.

A zero crossing point always exists on the curve with a single-photon detuning from 10 to 950 MHz. The offset can be adjusted in a large range, which sensitively depends on the buffer gas pressure. Generally, a higher buffer gas pressure can induce a larger offset range. However, we should avoid the use of significantly high pressures because the signal will become extremely weak under high pressure.

To evaluate the proposed scheme performance, error signal is recorded for 10 min, as shown in Fig. 4. The frequency of the coupling light varies in a wide range when it is free running. After locking, the relative frequency fluctuation is about 1 MHz. The frequency fluctuation of the probe light can be suppressed at below 1 MHz. The coupling light has a stable frequency at below 2 MHz. The AOM frequency is 160 MHz, i.e., the detuning of the probe light is 160 MHz. In the experiment, we only control the cavity length of the lasers that could be improved by adding current feedback.

In conclusion, we experimentally demonstrate a laser frequency offset locking method using buffer gas-induced resonance. The zero crossing error signal is produced without modulation and is detected using a single detector, which makes it more convenient than other modulation-free schemes. The narrow error signal makes the laser more stable. The power of the locked laser is unlimited and weakly attenuated, which is important for experiments in which high power is required.

This work was supported by the National Natural Science Foundation of China (Nos. 60925022, 10804097, and 11104243), the National “973” Program of China (No. 2013CB329501), and the Fundamental Research Funds for the Central Universities (No. 2012FZA3001).

References

1. S. Chu, L. Hollberg, J. Bjorkholm, A. Cable, and A. Ashki, *Phys. Rev. Lett.* **55**, 48 (1985).

2. E. Raab, M. Prentiss, A. Cable, S. Chu, and D. Pritchard, *Phys. Rev. Lett.* **59**, 2631 (1987).
3. D. M. Giltner, R. W. McGowan, and S. A. Lee, *Phys. Rev. Lett.* **75**, 2638 (1995).
4. M. Kasevich and S. Chu, *Phys. Rev. Lett.* **67**, 181 (1991).
5. X. Shan, X. Sun, J. Luo, Z. Tan, and M. Zhan, *Appl. Phys. Lett.* **89**, 191121 (2006).
6. J. Wang, Y. Zhu, K. Jiang, and M. Zhan, *Phys. Rev. A* **68**, 063810 (2003).
7. J. Zhan, J. Xu, G. Hernandez, X. Hu, and Y. Zhu, *Phys. Rev. A* **75**, 043810 (2007).
8. G. Yang, P. Xu, J. Wang, Y. Zhu, and M. Zhan, *Phys. Rev. A* **82**, 045804 (2010).
9. F. B. J. Buchkremer, R. Dumke, C. Buggle, G. Birkl, and W. Ertmer, *Rev. Sci. Instrum.* **71**, 3306 (2000).
10. M. Kasevich, D. S. Weiss, E. Riis, K. Moler, S. Kasapi, and S. Chu, *Phys. Rev. Lett.* **66**, 2297 (1991).
11. R. L. Barger and J. L. Hall, *Phys. Rev. Lett.* **22**, 4 (1969).
12. U. Schünemann, H. Engler, R. Grimm, M. Weidemüller, and M. Zielonkowski, *Rev. Sci. Instrum.* **70**, 242 (1999).
13. P. Bohlouli-Zanjani, K. Afrousheh, and J. D. D. Martin, *Rev. Sci. Instrum.* **77**, 093105 (2006).
14. N. Seymour-Smith, P. Blythe, M. Keller, and W. Lange, *Rev. Sci. Instrum.* **81**, 075109 (2010).
15. H. S. Moon, L. Lee, K. Kim, and J. B. Kim, *Appl. Phys. Lett.* **84**, 3001 (2004).
16. S. C. Bell, D. M. Heywood, J. D. White, J. D. Close, and R. E. Scholten, *Appl. Phys. Lett.* **90**, 171120 (2007).
17. R. P. Abel, A. K. Mohapatra, M. G. Bason, J. D. Pritchard, K. J. Weatherill, U. Raitzsch, and C. S. Adams, *Appl. Phys. Lett.* **94**, 071107 (2009).
18. F. E. Becerra, R. T. Willis, S. L. Rolston, and L. A. Orozco, *J. Opt. Soc. Am. B* **26**, 1315 (2009).
19. A. L. Marchant, S. Händel, T. P. Wiles, S. A. Hopkins, C. S. Adams, and S. L. Cornish, *Opt. Lett.* **36**, 010064 (2011).
20. E. E. Mikhailov, I. Novikova, Y. V. Rostovtsev, and G. R. Welch, *Phys. Rev. A* **70**, 033806 (2004).
21. F. Levi, A. Godone, J. V. S. Micalizio, and G. Modugno, *Eur. Phys. J. D* **12**, 53 (2000).
22. S. Knappe, M. Stahler, C. Affolderbach, A. V. Taichenachev, V. I. Yudin, and R. Wynands, *Appl. Phys. B* **76**, 57 (2003).
23. C. Wieman and T. W. Hänsch, *Phys. Rev. Lett.* **36**, 1170 (1976).
24. J. B. Kim, H. J. Kong, and S. S. Lee, *Appl. Phys. Lett.* **52**, 417 (1988).
25. G. Yang, X. Chen, J. Wang, and M. Zhan, *Chin. Opt. Lett.* **8**, 1095 (2010).