

Dual-source distributed optical fiber sensor for simultaneous temperature and strain measurements

Fuchang Chen (陈福昌)*, Jiacheng Hu (胡佳成), Chengtao Zhang (张承涛), and Zunqi Lin (林尊琪)

National Laboratory of High Power Laser Physics, Shanghai Institute of Optics and Fine Mechanics,
Chinese Academy of Sciences, Shanghai 201800, China

*Corresponding author: ouch27@163.com

Received September 28, 2011; accepted December 28, 2011; posted online March 5, 2012

A dual-source distributed optical fiber sensor system with combined Raman and Brillouin scatterings is designed for simultaneous temperature and strain measurements. The optimal Raman and Brillouin signals can be separately obtained by adjusting the powers of the two sources using an optical switch. The temperature and strain can be determined by processing the optimal Raman and Brillouin signals. The experimental result shows that 1.7 °C temperature resolution and 60- $\mu\epsilon$ strain resolution can be achieved at a 24.7-km distance.

OCIS codes: 060.2370, 290.5860, 290.5830.

doi: 10.3788/COL201210.060601.

Recently, intensive research has been aimed at the development of distributed optical fiber sensors (DOFSs) because of their notable advantages such as continuous strain and temperature measurements, and strong resistance to electromagnetic interference and corrosion. Some primary applications have been made in monitoring large structures such as dams, tunnels, pipelines, oil wells, bridges, landslides, etc^[1]. In the DOFS system based on the Brillouin optical time domain reflectometry (BOTDR) technique, temperature and strain variations can be measured using the Brillouin frequency shift combined with a change in Brillouin intensity. However, the accuracy of the intensity measurement limits the performance of long-range combined temperature and strain sensors^[2]. The Brillouin frequency shift is dependent on both temperature and strain, whereas the Raman signal is only sensitive to temperature. Moreover, the intensity of the Raman signal exhibits more sensitivity to temperature ($\sim 0.8\%/^{\circ}\text{C}$)^[3] than the anti-Stokes Brillouin signal ($\sim 0.36\%/^{\circ}\text{C}$)^[2]. Thus, the Brillouin intensity can be replaced by the Raman intensity. The temperature along the fiber can be determined using the Raman intensity, whereas the strain can be computed using the Brillouin frequency shift. Commercial Raman distributed temperature sensors can now readily achieve 1 °C temperature resolution for a 30-km distance^[4]. Therefore, the temperature resolution and strain would be greatly improved if the Raman distributed temperature sensor is combined with Brillouin frequency measurement. In this letter, we propose a method for measuring the anti-Stokes Raman intensity and Brillouin frequency shift generated from dual sources with optimal output optical power to obtain the temperature and strain along the fiber.

The DOFS system for simultaneous temperature and strain measurements is shown in Fig. 1. The seed laser light radiated from the distributed feedback laser diode (DFB-LD) is split using a 90/10 coupler, with 10% of the power used to produce the local oscillator (LO) for coherent detection and 90% of the power amplified by the erbium-doped fiber amplifiers (EDFAs). The continuous light is converted to pulse light using the acousto-

optic modulator (AOM) and amplified using EDFA2. After passing through the circulator (C1), the pulse light is launched into the fiber for measurement. The polarization scrambler (PS) is used to reduce polarization noise^[5]. The spontaneous Raman and Brillouin backscattered signals generated along the fiber is fed back through C1 and launched into the wavelength-division multiplexer (WDM), which divides the two backscattered signals. The separated anti-Stokes Raman signal is received by the direct detection system, whereas the anti-Stokes Brillouin backscattered signal is amplified using EDFA3. The amplified spontaneous emission (ASE) and Rayleigh noises are eliminated from the Brillouin backscattered signal using the filter composed of a fiber Bragg grating (FBG) and circulator (C2)^[6]. The filtered Brillouin backscattered signal and LO are launched into the 50/50 coupler. The interaction between the Brillouin backscattered signal and LO generates a Brillouin-shifted frequency signal, which is detected by the coherent detection system. The anti-Stokes Raman signal is only sensitive to temperature, and the Raman intensity change is proportional to the temperature change^[3]. Thus, the anti-Stokes Raman intensity change obtained from the direct detection system can be expressed as

$$\Delta I_R(L) = C_R^T \Delta T_R(L), \quad (1)$$

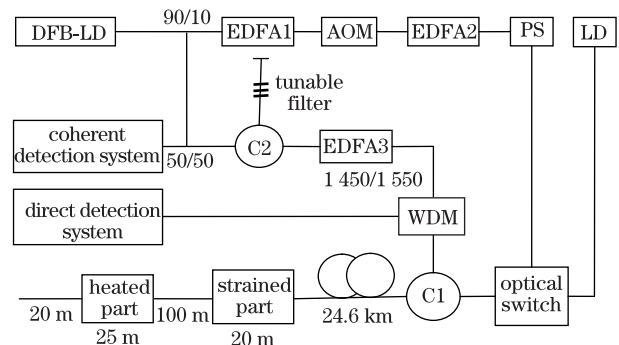

Fig. 1. Experimental setup for measuring both Raman intensity and Brillouin frequency shifts.

where L is the distance along the fiber, $\Delta T_R(L)$ is the temperature variation, and C_R^T is the temperature coefficient of the Raman intensity change. The value of C_R^T is taken to be $0.76\%/^{\circ}\text{C}$.

In the coherent detection system, the Brillouin frequency shift can be obtained as

$$\Delta\nu_B(L) = C_{B\nu}^T \Delta T_R(L) + C_{B\nu}^{\varepsilon} \Delta\varepsilon(L), \quad (2)$$

where $\Delta\varepsilon(L)$ is the strain variation, and $C_{B\nu}^T$ and $C_{B\nu}^{\varepsilon}$ are the temperature and strain coefficients, respectively, for the Brillouin frequency shift^[2]. These two coefficients are $\sim 1.2 \text{ MHz}/^{\circ}\text{C}$ and $\sim 0.04 \text{ MHz}/\mu\varepsilon$, respectively^[7].

The temperature variation $\Delta T_R(L)$ can be obtained using the Raman anti-Stokes intensity change in Eq. (1) as

$$\Delta T_R(L) = \frac{\Delta I_R(L)}{C_R^T}. \quad (3)$$

Thus, the strain of the fiber $\Delta\varepsilon(L)$ can be computed using the Brillouin frequency shift $\Delta\nu_B(L)$ with $\Delta T_R(L)$ obtained as

$$\Delta\varepsilon(L) = \frac{\Delta\nu_B(L) - C_{B\nu}^T \Delta T_R(L)}{C_{B\nu}^{\varepsilon}}. \quad (4)$$

An improved signal-to-noise ratio (SNR), which is achieved by increasing the intensity of the spontaneous Raman and Brillouin scattering signals, improves the resolution of the sensors. The power of the light sources should be adjusted near the stimulated scattering threshold to obtain the optimal Raman and Brillouin signals. However, the threshold of stimulated Brillouin scattering (SBS)^[8] is much smaller than that of stimulated Raman scattering (SRS). Thus, these two optimal scattered signals cannot be obtained simultaneously using a single laser source. As shown in Fig. 1, an additional LD is used in the DOFS system. The power of the DFB-LD is tuned to the SBS threshold, whereas the power of the LD is tuned to the SRS threshold. Using the optical switch, the system is controlled to work alternately in two modes. In the direct detection mode, the laser beam radiated from the LD passes through the optical switch, whereas the direct detection system detects the Raman anti-Stokes signal. Considering that the LD is operating in the power near the SRS threshold, the optimal Raman anti-Stokes signal can be obtained using

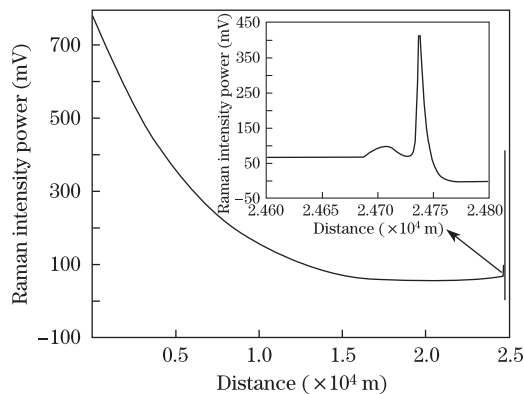

Fig. 2. Raman anti-Stokes intensity trace along the sensing fiber.

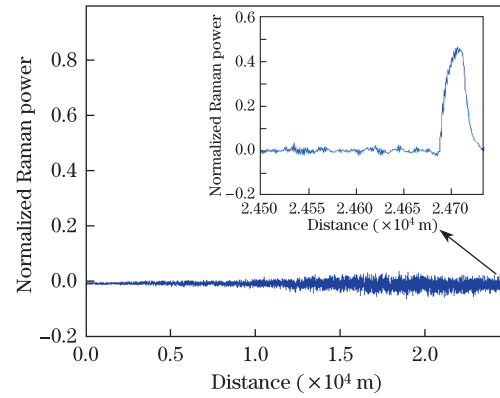

Fig. 3. Raman normalized power profile along the sensing fiber.

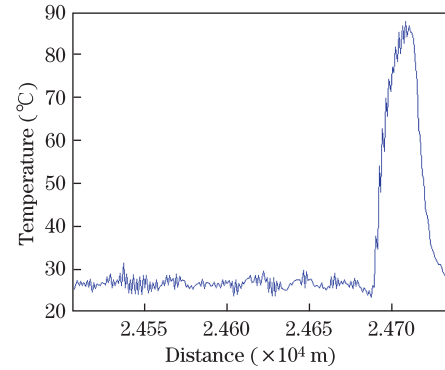

Fig. 4. Temperature profile around the heated and strained parts.

the direct detection system with which the temperature variation $\Delta T_R(L)$ can be calculated. In the coherent detection mode, the laser beam radiated from the DFB-LD passes through the optical switch, whereas the coherent detection system detects the Brillouin frequency shift signal. Considering that the DFB-LD is fixed in the power near the SBS threshold, the optimal Brillouin scattered signal can be obtained using the coherent detection system. With the calculated result of $\Delta T_R(L)$ in the direct detection mode, the strain of the fiber $\Delta\varepsilon(L)$ can be determined.

The DFB-LD is an approximately 1 543.7-nm optical-fiber DFB laser, with a line width of less than 100 kHz. The probe light with 100-ns pulsewidth and 2-kHz repetition rate generated by the AOM in conjunction with EDFA1 and EDFA2 is amplified to 75 mW near the SBS threshold. The LD is a high-speed pulsed light source with a 1 547.1-nm wavelength and 3-MHz line width. The power of the probe pulse light with 100-ns pulsewidth and 2-kHz repetition rate generated by the LD is 0.9 W near the SRS threshold. The center wavelength of the FBG with 98% reflectivity and 3-dB bandwidth at 0.09 nm was tuned to about 1 543.6 nm and fixed around the Brillouin frequency. The fiber measured is a 24.7-km single-mode fiber (SMF) composed of five parts, as shown in Fig. 1. The first 24.6 km remained in a loose state on the original spools at room temperature (27°C). The subsequent 20 m was passed around four pairs of pulleys and loaded with weights. The next 100 m was subject to room temperature and zero strain as a reference. The following

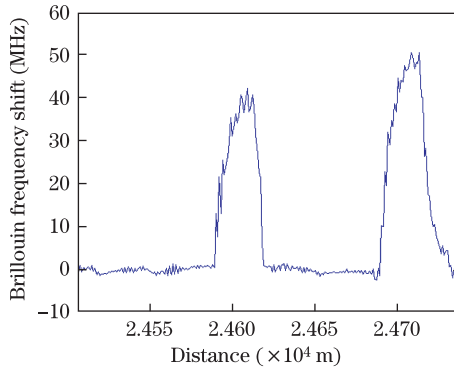

Fig. 5. Brillouin frequency shifts around the heated and strained parts normalized to room temperature and zero strain.

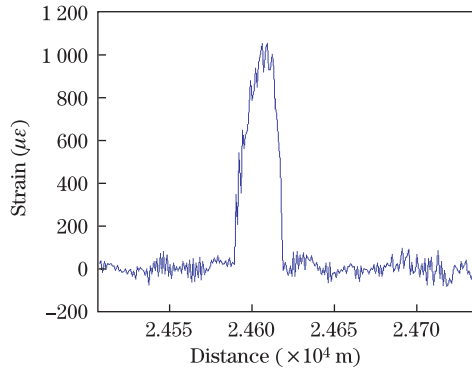

Fig. 6. Strain profile around the heated and strained parts.

25 m was placed in an oven at 85 °C^[9], and the remaining 20 m was used to prevent end-face reflection.

In the coherent detection system, the Brillouin spectra were obtained by taking time-domain backscattering traces for a series of beat frequencies, covering the expected Brillouin frequency shifts^[10]. After each set of spectra was obtained, the frequency shift of the Brillouin backscatter was determined for each point of interest along the fiber by fitting each individual spectrum to a Lorentzian curve, considering that the spontaneous Brillouin line is known to be of this shape. These spectra were obtained by taking a series of 60 different backscatter traces, each separated by 2.5 MHz, starting at 10.87 GHz. Each trace was averaged 4 096 times. In the direct detection system, the Raman signal was averaged 250 000 times. The signal was acquired using a digital-to-analog converter called PCI-ADD (Shanghai Transient Electronics Technology Co. Ltd).

Figure 2 shows the plot of the Raman backscatter intensity measurement at 1 450 nm over the entire sensing length. The heated part is visible near 24.7 km. The inset of Fig. 2 shows an enlarged scale of the Raman intensity near the heated and strained parts.

Figure 3 shows the trace of the normalized Raman power, which is normalized by using a trace obtained before the fiber is heated.

Then, the temperature trace along the fiber was determined by the normalized Raman intensity change in

Eq. (3). Figure 4 shows the temperature profile along the sensing fiber. The RMS temperature resolution at the heated part was calculated as 1.7 °C.

Figure 5 shows the Brillouin frequency shift for both heated and strained parts relative to the loose fiber at room temperature. The RMS resolution of the Brillouin frequency shift at the unheated and unstrained parts is less than 0.8 MHz, which is equivalent to a temperature error of less than 0.7 °C or a strain error of less than 20 με.

Although the temperature along the fiber is known, the strain is determined using Eq. (4). Figure 6 shows the strain profile around the heated and strained parts. The RMS resolution at the strained part was calculated as 60 με.

The noise in the temperature and strain measurements is due to both the circuit noise and the contamination of the Raman signal with coherent Rayleigh noise. Noise can be reduced in several ways. One method is by increasing the averaging times, and another is by improving the filtering process and further attenuating the Rayleigh contamination. Wavelet denoising is also a reasonable and promising way to reduce noise.

In conclusion, a dual-source DOFS for the simultaneous temperature and strain measurements based on Raman and Brillouin scattering is demonstrated. The temperature along the sensing fiber is determined using the optimal Raman signal, which is independent of strain, whereas the strain is obtained using the Brillouin frequency shift. By using accumulative averaging and by obtaining the optimal Raman and Brillouin signals, a RMS temperature resolution of ~1.7 °C and a RMS strain resolution of ~60 με for a distance of 24.7 km are achieved.

References

1. Y. T. Cho, M. Alahbabi, M. J. Gunning, and T. P. Newson, *Opt. Lett.* **28**, 1651 (2003).
2. S. M. Maughan, H. H. Kee, and T. P. Newson, *Meas. Sci. Technol.* **12**, 834 (2001).
3. A. H. Hartog, A. P. Leach, and M. P. Gold, *Electron. Lett.* **21**, 1061 (1985).
4. Z. Zhang, H. Liu, J. Wang, X. Yu, Y. Jin, S. K. Insoo, and X. Wu, *Proc. SPIE* **5364**, 182 (2005).
5. M. Song and B. Zhuang, *Acta Opt. Sin.* (in Chinese) **27**, 711 (2007).
6. A. Sun, B. Chen, J. Chen, G. Li, L. Wang, L. Chang, and Z. Lin, *Opt. Eng.* **46**, 124401 (2007).
7. T. R. Parker, M. Farhadiroushan, V. A. Handerek, and A. J. Rogers, *Opt. Lett.* **22**, 787 (1997).
8. T. Kurashima, T. Horiguchi, and M. Tateda, *Opt. Lett.* **15**, 1038 (1990).
9. M. N. Alahbabi, Y. T. Cho, and T. P. Newson, *Opt. Lett.* **30**, 1276 (2005).
10. S. M. Maughan, H. H. Kee, and T. P. Newson, *Opt. Lett.* **26**, 331 (2001).