

Fiber nonlinearity compensation for CO-OFDM transmission with 10.7-Gb/s NRZ-OOK neighbors

Mingliang Deng (邓明亮)*, Xingwen Yi (易兴文), Jing Zhang (张静),
Hongbo Zhang (张洪波), and Kun Qiu (邱昆)

Key Laboratory of Optical Fiber Sensing and Communication Networks, Ministry of Education,
University of Electronic Science and Technology of China, Chengdu 611731, China

*Corresponding author: dengmingliang9@163.com

Received April 18, 2012; accepted June 20, 2012; posted online September 28, 2012

Fiber nonlinearity limits the use of coherent optical orthogonal frequency division multiplexing (CO-OFDM) to upgrade wavelength-division multiplexing (WDM) systems using legacy non-return-to-zero-on-off-keying (NRZ-OOK) channels. This letter proposes to compensate for the fiber nonlinearity of CO-OFDM with NRZ-OOK neighbors by combining digital signal processing (DSP)-based self-phase modulation (SPM) post-compensation with pilot-tone-based cross-phase modulation (XPM) compensation. The simulation results demonstrate that the optimum low-pass filter bandwidth for pilot-tone-based XPM compensation depends on the pilot-to-signal ratio value and launch optical power. Our method allows a 4-dB increase in the launch power for a 40-Gb/s single polarization CO-OFDM channel placed in the middle of six 10.7-Gb/s NRZ channels in a 50-GHz space and 1 200-km WDM system.

OCIS codes: 060.1660, 060.4370, 060.4080, 060.2330.

doi: 10.3788/COL201210.110602.

Coherent optical orthogonal frequency division multiplexing (CO-OFDM) is immune to linear impairments in optical fiber transmissions, such as chromatic dispersion (CD) and polarization mode dispersion (PMD)^[1,2]. However, fiber nonlinearities for long-haul CO-OFDM transmission systems restrict the optical power launched into each fiber span and the transmission distance^[3,4]. Thus, several studies have been devoted to the nonlinearity compensation for CO-OFDM systems^[5–7].

In legacy wavelength-division multiplexing (WDM) optical networks, non-return-to-zero-on-off-keying (NRZ-OOK) is the dominant modulation format, and the periodic dispersion map is used to compensate for CD. In these optical networks, CO-OFDM can be used to upgrade a few wavelengths. The mixed modulation formats can then coexist in one optical link. However, the fiber nonlinearity performance of CO-OFDM is poor in such networks due to self-phase modulation (SPM)^[8] and cross-phase modulation (XPM) from the NRZ neighbors operated at 10.7 Gb/s^[9]. Therefore, fiber nonlinearity compensation for the CO-OFDM channel is useful. Using the phase modulation proportional to the bandwidth-limited received intensity on all channels to cancel cross-phase modulation XPM caused by NRZ neighbors was proposed in Ref. [10], and the nonlinearity threshold was improved to about 2 dB.

In this letter, the effectiveness of digital signal processing (DSP)-based SPM post-compensation and pilot-tone (PT)-based XPM compensation is demonstrated to mitigate the fiber nonlinear impairments of CO-OFDM transmission with 10.7-Gb/s NRZ neighbors in the conventional WDM system. The optimum low-pass filter (LPF) bandwidth for PT-based XPM compensation was also shown to depend on the pilot-to-signal ratio (PSR) at different launch optical powers, which is different from the PT-aided phase noise compensation in Ref. [2]. In a numerical simulation of a 50-GHz spacing and 1 200-km

WDM transmission with inline dispersion compensation, the optimum launch power for a 40-Gb/s CO-OFDM channel placed in the middle of six 10.7-Gb/s NRZ channels is increased by 4 dB, and the Q -factor can also be improved by 1.5 dB at the optimal operational power. Meanwhile, no penalty was found in the amplified simultaneous emission (ASE) limited linear region using optimum PSR values and LPF bandwidths for PT extraction.

The fiber nonlinear impairments of the CO-OFDM channel with NRZ neighbors predominantly consist of SPM caused by intensity fluctuation of the CO-OFDM channel and the XPM induced by NRZ neighbors. SPM can be partially removed by imposing a phase modulation proportional to the instantaneous received CO-OFDM channel power before the fast Fourier transform (FFT) in the OFDM receiver^[11]. This phase modulation can be expressed as $S_1(t) = S_{Rx}(t)e^{-j\beta|S_{Rx}(t)|^2}$, where $S_1(t)$ is the SPM mitigated CO-OFDM signal, $S_{Rx}(t)$ is the time domain signal of the CO-OFDM channel at the receiver, and β is a phenomenological nonlinear factor that can be estimated without the fiber link information. The optimal β can be estimated, for instance, based on the maximum Q -factor of the received constellation or the minimum received bit error rate (BER). Due to the CD-caused walk-off of the subcarriers in OFDM signal, the intensity fluctuations of the highest frequency subcarriers have a minimal contribution to the nonlinear degradation^[12]. Thus, a digital LPF is introduced to restrict the bandwidth of the compensation signal. The block diagram and algorithm of SPM compensation are depicted in Fig. 1.

PT-based nonlinearity compensation is similar to the PT-aided phase noise compensation in Ref. [2]. This compensation was proposed for the case of fiber nonlinearities in CO-OFDM WDM systems in Refs. [13–15]. The PT-based nonlinearity compensation is only

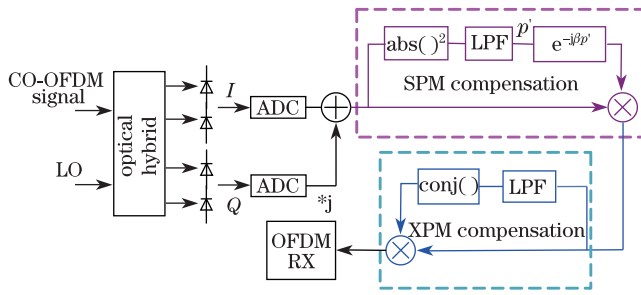

Fig. 1. Block diagram of the nonlinearity compensation and DSP algorithms.

proposed to aid the XPM degradation of the CO-OFDM channel contributed by NRZ neighbors. An unmodulated PT at the CO-OFDM transmitter is inserted at the center of OFDM spectrum and zeros are placed on several subcarriers around the PT as the guard band. The PT and other modulated OFDM subcarriers along the fiber link are affected by the neighboring NRZ channels due to XPM in the same manner. The PT filtered by a digital LPF is conjugated and multiplied with the OFDM signal in the time domain to remove the XPM phase noise after SPM compensation, as shown in Fig. 1. One feature of this XPM compensation is that it can be implemented digitally without the knowledge of neighboring NRZ channels. Both the bandwidth of LPF and PSR influence the performance of this XPM compensation. PSR is defined as $PSR = 10 \lg(P_{PT}/P_{OFDM})$, where P_{PT} and P_{OFDM} represent the electrical power of PT and OFDM signal, respectively. The LPF bandwidth must be narrow enough to minimize the influence of the ASE noise and sufficiently wide to include the PT broadened by XPM. The PSR should also have an optimum value because the PT is too weak for lower PSR and the ASE noise reduces the efficiency of XPM compensation, whereas the OSNR of OFDM signal becomes too low for higher PSR. The PT-based XPM compensation must be carried out after SPM post-compensation. If PT-based XPM compensation was placed first, it would compensate for the XPM and partial SPM because the SPM phase noise was not captured by PT completely^[15]. A second SPM compensation caused by the subsequent SPM post-compensation would degrade the performance.

The commercial software VPItransmissionMaker8.3 was used to carry out a numerical simulation to verify the benefit of DSP-based SPM post-compensation and PT-based XPM compensation for CO-OFDM transmission with legacy NRZ channels in a WDM system. Figure 2(a) shows the simulation setup. A single polarization 41.2-Gb/s (net data rate after 7% forward error correction (FEC)) CO-OFDM system, with 27-GHz optical bandwidth, was generated using 512-point inverse FFT (IFFT), with 1/8 length of FFT window for cyclic prefix. 297 data subcarriers are modulated with 4-QAM (quadrature amplitude modulation) and the other subcarriers, including 12 subcarriers on both sides of DC, are zeroed. The zero-subcarriers around DC result in a 2-GHz gap in the middle of the OFDM spectrum left for the PT insertion. Laser phase noise was not included in the simulation. The CO-OFDM transmission system was simulated on the central channel with six 10.7-Gb/s NRZ neighbors, with three placed on each

side. All WDM channels were on the same polarization and placed on a 50-GHz grid. All channels were kept at equal launch optical powers to quantify the penalty introduced by the NRZ-caused XPM.

The transmission link, similar to that used in Ref. [10], consists of a 1200-km standard single mode fiber (SSMF) link of 15 spans, with a near optimum periodic dispersion map illustrated in Fig. 2(b) that includes -1000 ps/nm of pre-compensation and 100 ps/nm of residual dispersion per span. The accumulated residual dispersion was compensated electrically with the help of the cyclic prefix. The dispersion compensation fiber (DCF) was modeled with -89.285-ps/(nm·km) dispersion, 0.6-dB/km attenuation, and 25- μm^2 effective area. The dispersion coefficient, attenuation, fiber nonlinearity refractive index, and effective area of SSMF were 17.857 ps/(nm·km), 0.2 dB/km, 2.6×10^{-20} m²/W, and 80 μm^2 , respectively. EDFAs (6-dB noise figure) were used to compensate for losses. The launch power into DCF was 8 dB less than that into SSMF to minimize the fiber nonlinearities in DCF.

The trapezoidal digital LPF, with characteristics shown in Fig. 2(c), was introduced to limit the bandwidth of the compensation signals in Fig. 1. The optimal bandwidth for SPM compensation was about 5 GHz, independent of the PSR value for the simulated CO-OFDM channel below at different launch powers. The optimal bandwidth for the XPM compensation of LPF for PT extraction depends on the PSR value and launched optical power.

Figure 3(a) depicts the typical received WDM optical spectrum with launch power to each SSMF fiber span of -2 dBm/channel. The PT in the zoomed received optical spectrum of the CO-OFDM channel shown in Fig. 3(b) was clearly broadened by XPM compared with the transmitted optical spectrum. However, the pedestal around the OFDM spectrum caused by SPM was not obvious because it was masked by the OFDM spectrum roll-off.

Figure 4(a) shows the Q -factor of the XPM mitigated CO-OFDM channel plotted against the bandwidth of LPF used to extract PT for three PSR values at launch power of -2 dBm/channel. The optimal bandwidths for -12 and -4 dB PSRs were 600 and 900 MHz, respectively. These bandwidths indicate that the optimum LPF bandwidths are unequal for different PSR values at an explicit launch optical power. Figure 4(b) depicts the Q -factor of the SPM and XPM mitigated CO-OFDM channel for different bandwidths of LPF used for XPM compensation at -8-dB PSR configuration. The optimal bandwidths at launch powers of -4 and -6 dBm were 600 and 400 MHz, respectively, indicating that the optimum LPF bandwidths also varied at different launch optical powers for a determinate PSR value. Figure 4 shows that the optimum LPF bandwidth for PT-based XPM compensation depends on the PSR value and launch optical power, which is different from the PT-aided phase noise compensation in Ref. [2], where the optimal LPF bandwidth was a constant at each launch power for different PSR configurations. This result suggests that the PT-based XPM compensation needs to be adaptive.

A sweep of PSR configurations was applied to each launch optical power and corresponding optimal LPF bandwidths are swept to obtain the best efficiency of

the XPM compensation. Figure 5 illustrates the optimum PSR values and LPF bandwidths for different launch optical powers between -14 and 2 dBm/channel. The optimum PSR values in the ASE limited region, from -14 to -8 dBm, were lower and optimum bandwidths are zeros without PT-based XPM compensation because small nonlinear phase noise was generated and ASE noise degraded the PT. The optimized PSRs and bandwidths in the nonlinearity limited region increased abruptly, suggesting that more optical power can be allocated to the PT and the XPM broadens PTs significantly.

Figure 6 demonstrates the benefit of this joint nonlinearity compensation. The traces of the single 40-Gb/s

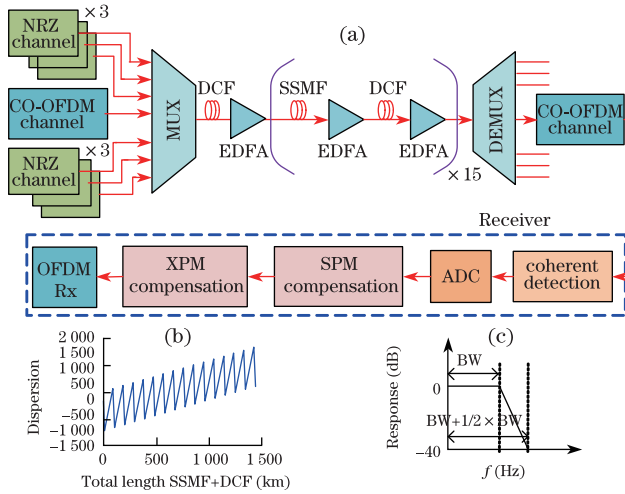

Fig. 2. (a) Simulation setup for fiber nonlinearity compensation; (b) dispersion map of the simulated link; (c) the characteristics of digital LPFs.

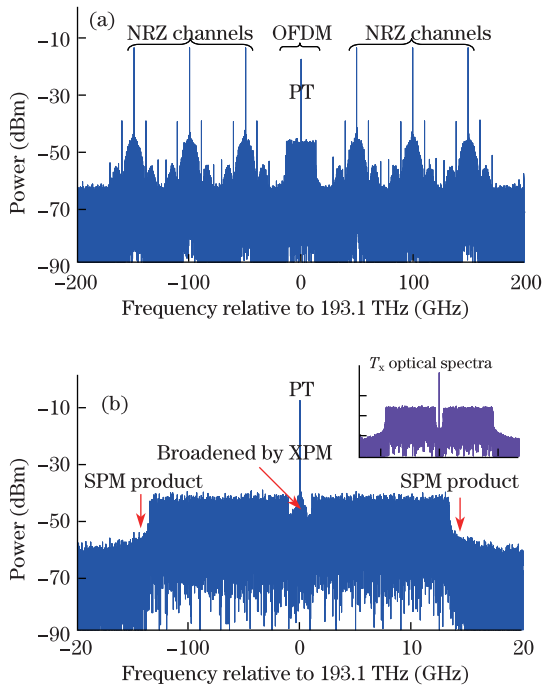

Fig. 3. (a) Received optical spectrum of WDM system; (b) zoom in of the CO-OFDM channel with PT. The inset is the transmitted spectrum for comparison.

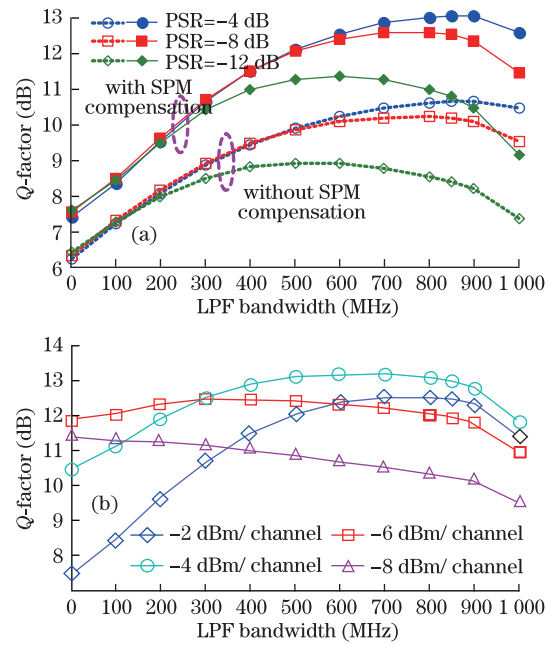

Fig. 4. (a) Q -factor versus LPF bandwidth for different PSRs at launch power of -2 dBm/channel; (b) Q -factor versus LPF bandwidth at different launch powers for -8 -dB PSR.

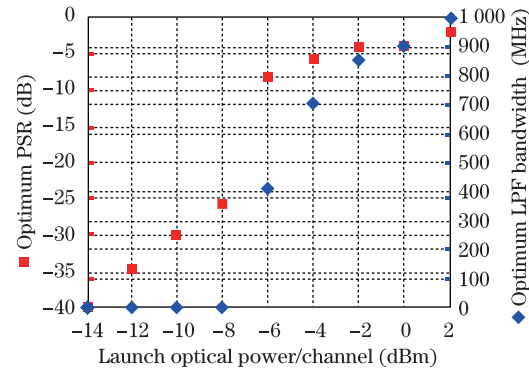

Fig. 5. (Color online) PSR and LPF bandwidth optimization for different launch powers/channel.

CO-OFDM channel in Fig. 6(a) indicate that the DSP-based SPM post-compensation can offer up to a 2-dB improvement of Q -factor and a 3-dB increase of the launch optical power. The bottom trace also shows that the optimum Q -factor and optimum launch power of this CO-OFDM channel with NRZ neighbors were reduced to 11.8 dB and -7 dBm, respectively. The nonlinearity compensation improved the performance by 1.5 dB and increased the optimum launch optical power to -3 dBm, which was identical to that of the single CO-OFDM channel. Figure 6(b) illustrates the received constellations with and without nonlinearity compensation at launch power of -2 dBm/channel with the optimal β , PSR configuration, and LPF bandwidth for the PT extraction. Optimum PSR values were used at different launch powers; thus, the Q penalties of the proposed method in the ASE limited region were almost zeros compared with the 0.8-dB penalty in Ref. [14] and 1 dB penalty in Ref. [15], where the constant PSR value was adopted at all launch optical powers.

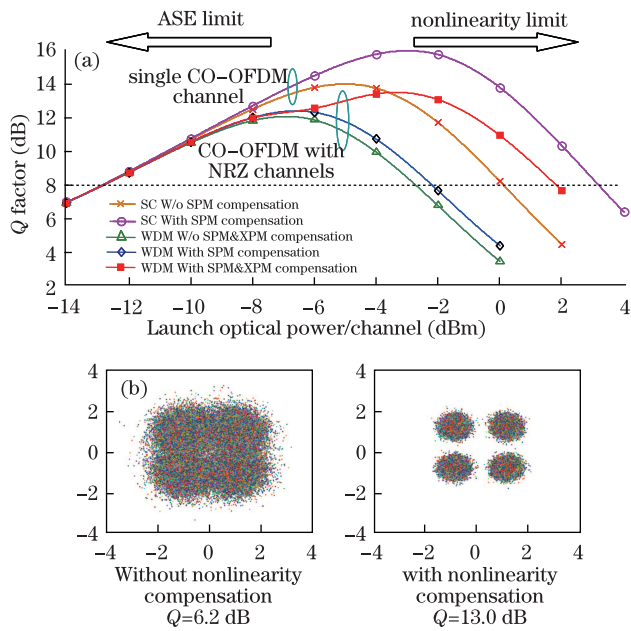

Fig. 6. (a) Q -factor versus launch power for single CO-OFDM channel with or without NRZ neighbors; (b) the constellations of nonlinearity compensation on and off at launch power of -2 dBm/channel.

The polarizations of all the WDM channels were aligned in the simulation, which was the worst scenario when the system performance was limited by fiber nonlinearity due to the stronger XPM effect than that of the polarization misaligned scenario. The proposed nonlinearity compensation method was expected to still work efficiently in real WDM networks, where the improvement using our method may be smaller since the XPM was weaker.

In conclusion, the joint implementation of DSP-based SPM post-compensation and PT-based XPM compensation for nonlinear mitigation of CO-OFDM transmission with 10.7-Gb/s NRZ neighbors in the conventional WDM system is proposed. The optimum LPF bandwidth for PT-based XPM compensation depends on the PSR value and launch optical power. A 4-dB improvement in the optimal launch power and a 1.5-dB increase of Q -factor

for a CO-OFDM channel with six NRZ neighbors are observed after a 1200-km SSMF transmission on a 50-GHz WDM grid. This nonlinearity compensation can be implemented digitally without the knowledge of neighboring NRZ channels and generate no penalty in an ASE limited region by PSR optimization.

This work was supported by the National Natural Science Foundation of China (Nos. 61071097 and 61107060) and the State Key Laboratory of Advanced Optical Communication Systems and Networks.

References

1. W. Shieh, *IEEE Photon. Technol. Lett.* **19**, 134 (2007).
2. S. L. Jansen, I. Morita, T. C. W. Schenk, N. Takeda, and H. Tanaka, *J. Lightwave Technol.* **26**, 6 (2008).
3. A. J. Lowery, L. B. Du, and J. Armstrong, *J. Lightwave Technol.* **25**, 131 (2007).
4. X. Zhu and S. Kumar, *Opt. Express* **18**, 7347 (2010).
5. L. Li, Y. Qiao, and Y. Ji, *Chin. Opt. Lett.* **9**, 060604 (2011).
6. X. Chen, X. Liu, S. Chandrasekhar, B. Zhu, and R. W. Tkach, in *Proceedings of OFC 2012 OTh3C.1* (2012).
7. Y. Hao, Y. Li, R. Wang, and W. Huang, *Chin. Opt. Lett.* **10**, 010701 (2012).
8. K. Forozesh, S. L. Jansen, S. Randel, I. Morita, and H. Tanaka, in *Proceedings of IEEE/LEOS Summer Topical Meetings 2008* 135 (2008).
9. H. Chen, L. B. Du, and J. Armstrong, in *Proceedings of OECC/ACOFT 2008* 1 (2008).
10. L. B. Du and A. J. Lowery, in *Proceedings of OFC 2010 OTuE7* (2010).
11. W. Shieh, X. Yi, Y. Ma, and Y. Tang, *Opt. Express* **15**, 9936 (2007).
12. L. B. Du and A. J. Lowery, *Opt. Express* **16**, 19920 (2008).
13. B. Inan, S. Randel, S. L. Jansen, A. Lobato, S. Adhikari, and N. Hanik, in *Proceedings of ECOC2010 Tu.4.A.6* (2010).
14. L. B. Du and A. J. Lowery, *Opt. Lett.* **36**, 1647 (2011).
15. L. B. Du and A. J. Lowery, in *Proceedings of ECOC 2011 Th.11.B.4* (2011).