

Frequency-dispersive method for improving broad-band SBS phase conjugation of Cr:LiSAF laser

Chuanwen Ge (葛传文) and Weijun Zhang (张为俊)

Laser Spectroscopy Open Laboratory, Anhui Institute of Optics and Fine Mechanics,
Chinese Academy of Sciences, Hefei 230031

Received October 11, 2002

After passing through four dispersive-prisms, the *Q*-switched Cr:LiSAF laser with broad frequency band is focused into carbon disulfide (CS₂) to produce backward stimulated Brillouin scattering (SBS). Our experimental results and illustrative analysis have shown that this frequency-dispersive method can efficiently reduce the broad-band SBS intensity threshold, compress its pulsewidth, and improve the beam quality.

OCIS codes: 190.0190, 190.5040, 190.5890.

The tunable Cr:LiSAF solid laser with wide fluorescence band^[1] will be applied largely in many fields, such as atmospheric pollution monitor and undersea communication. But now most of Xe-lamp-pumped Cr:LiSAF lasers are multi-transverse and multi-longitude mode systems^[2], unsuitable for efficient driving of nonlinear optical harmonic processes^[3]. So the application fields of this kind of laser will be limited. In order to improve its beam quality, we have used stimulated Brillouin scattering (SBS) phase conjugation method in the broad-band Cr:LiSAF laser system.

As we know, narrow-band SBS is easy to realize low threshold. But many experimental investigations have shown that broad-band SBS has a very high threshold^[4,5]. The high pump intensity often gives rise to other nonlinear effects that compete with SBS, such as stimulated Raman scattering (SRS) and optical breakdown^[6]. So the phase conjugation of broad-band SBS is poor. M. R. Perrone and Y. B. Yao set a reflective grating in front of the SBS-cell of broad-band free-running XeCl laser and used the first order dispersed beam to pump SBS medium, their experimental results demonstrated that broad-band SBS performance can be improved^[7].

In the present paper, we replace the grating with four prisms to disperse broad-band Cr:LiSAF laser beam and call this a frequency-dispersive method. The experimental setup is shown schematically in Fig. 1.

Without any mode-selecting elements (such as F-P etalons or dispersive-prisms) in the resonator to narrow linewidth, the Xe-lamp-pumped and electro-optically *Q*-switched Cr:LiSAF laser's linewidth is about 5 nm, somewhat similar to the laser in Ref. [8].

With supplied pump voltage increasing from 750 to 900 V, the laser pulsewidth (FWHM) varies from 180 to 65 ns, but its amplitude becomes higher. Figure 2 shows the pulses for pump voltages of 800, 850 and 900 V, with their pulsewidths (FWHM) of about 100, 80 and 60 ns, respectively.

Because of internal damage in the Cr:LiSAF rod, the laser beam quality is very poor. Figure 3(a) shows its near-field spot (6 × 5 mm²) at 850-V pump voltage, burned in a gray photo-paper. It is obviously a multi-transverse mode structure, with its measured beam quality to be $M^2 \approx 3.5$. After passing through a polarizer

(Glan-Taylor polarizing beam-splitter), a $\lambda/4$ wave plate and four dispersive-prisms (P₁–P₄), it becomes a flat-long spot (20 × 5 mm²) as shown in Fig. 3(b), and the laser frequency band is dispersed along the longer direction. Then, through a 25-mm focal-length lens F_1 , we focus this dispersed laser beam into a SBS-cell filled with CS₂. As the laser intensity in focal region reaches SBS threshold, the SBS light is produced. The SBS beam propagates backward through the four prisms, $\lambda/4$ wave plate and polarizer, and comes out from a side of the polarizer. Here the polarizer and $\lambda/4$ wave plate form a optical isolator.

Using a piece of glass as beam-splitter, only a small proportion of SBS beam is reflected into a PIN fast photodiode for measuring its pulse shape. Figure 4 shows the SBS pulses for 800-, 850- and 900-V pump voltage, with their pulsewidths (FWHM) of 18, 15 and 12 ns, respectively. By comparison with the laser pulses in Fig. 2, we can see that pulsewidth compression ratio is about 5 times.

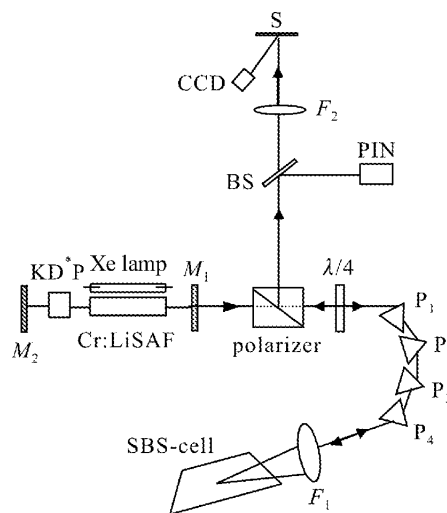

Fig. 1. Experimental setup. M_1 , M_2 : resonator mirrors; KD*P: *Q*-switching crystal; P₁, P₂, P₃, P₄: disperse-prisms; $\lambda/4$: quarter-wave plate; polarizer: Glan-Taylor polarizing beam-splitter; SBS-cell: SBS medium cell; BS: glass beam-splitter; PIN: fast photodiode; CCD: imaging camera; S: screen; F_1 , F_2 : lenses ($f_1 = 25$ mm, $f_2 = 250$ mm).

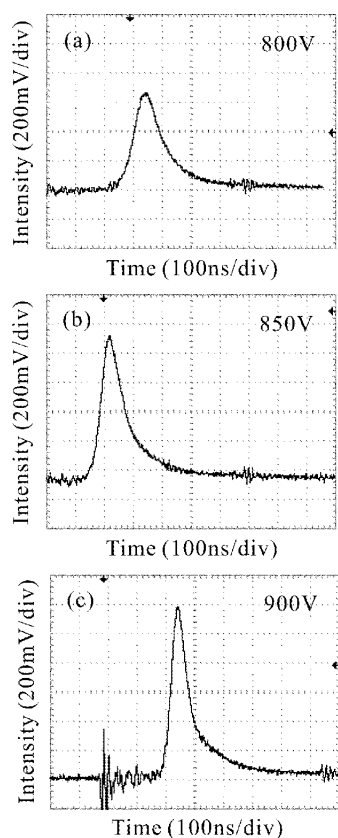

Fig. 2. Electro-optical Q -switched Cr:LiSAF laser's pulses for different pump voltages.

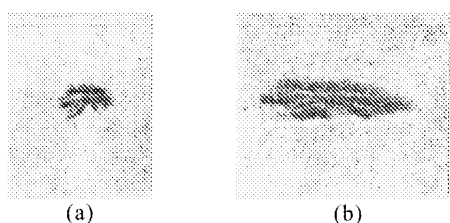

Fig. 3. Q -switched Cr:LiSAF laser's. (a) Near-field spot and (b) its dispersed flat-long spot.

Through the glass beam-splitter, the transmitting SBS beam is focused by lens F_2 with 250-mm focal-length onto a screen placed in the focal plane to form its far-field spot. The size of the far-field spot shows the quality of the backward SBS beam, i.e. the smaller or sharper spot shows the better quality of the SBS beam. The photographs of the far-field spots are taken with a CCD imaging camera, and Fig. 5 shows their three dimensional intensity profiles, their beam quality $M^2 \approx 1.5$. By comparison with the laser near-field spot in Fig. 3(a), these smaller M^2 have proved that the spatial quality of backward SBS beam is much higher than the laser beam.

Additionally, we have also measured the SBS energy threshold. In the case of focusing the dispersed Cr:LiSAF laser beam into SBS-cell, the threshold is about 15 mJ. But in the case of focusing the undispersed laser beam into SBS-cell, threshold is above 30 mJ. This experimental result has confirmed that frequency-dispersive method can reduce the broad-band SBS energy

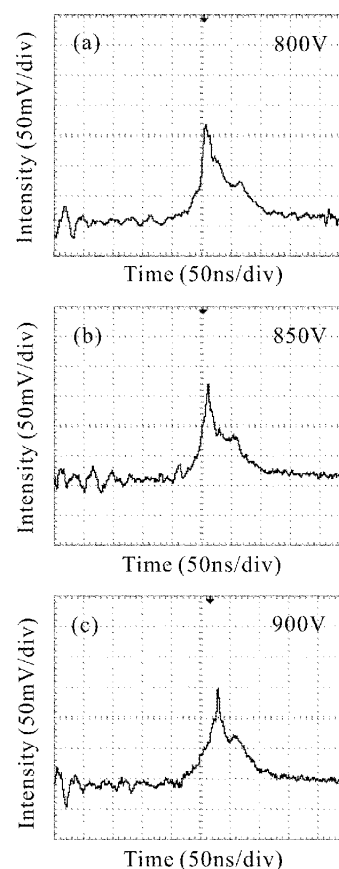

Fig. 4. Backward stimulated Brillouin scattering's pulses for different pump voltages.

threshold efficiently.

In the following we give a illustrative analysis for this frequency-dispersive method. Without mode selection, our Q -switched Cr:LiSAF laser beam consists of a large number of discrete frequencies modes determined by the length of resonator and the wide fluorescence spectral band of active material^[9]. In optical medium, the lower frequency light wave travels generally faster than the higher frequency one, and the former is deflected less than the latter. So at the focal region in SBS-cell, the focal spots of different frequency components are spread along the optical axis, as shown in Fig. 6(a), here ν_0 is the central frequency of laser beam, and $\Delta\nu$ is its linewidth. If $\Delta\nu$ is a broad-band, there will be a great many focal spots between the two focal spots of the highest and lowest frequency, and their density acoustic gratings superpose and erase each other, so make the broad-band SBS very inefficient. But, if we disperse firstly the broad frequency band of laser, and then focus the dispersed beam into SBS-cell, the focal spots of different frequency lights will be spread as shown in Fig. 6(b). In the case, every frequency component light can form relatively independent density acoustic gratings, reduce their inter-superposition and interference, and improve the broad-band SBS phase conjugation.

Actually, due to the threshold effect^[10] of stimulated scattering, backward SBS often do not reverse all transversal and longitudinal modes of pump laser beam for a complete phase conjugation. In our experiment,

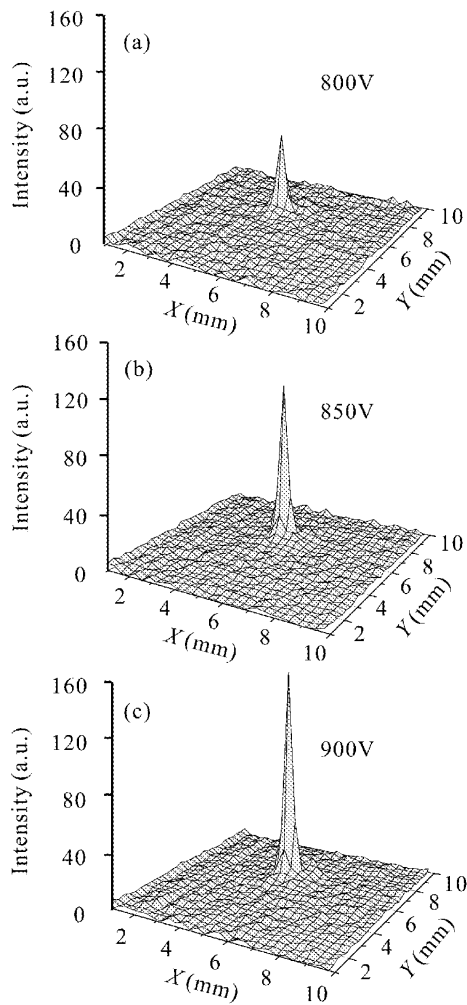

Fig. 5. Three-dimensional backward SBS far-field profiles at focal plane of lens F_2 .

after passing through the polarizer, $\lambda/4$ wave plate and four prisms, the pump laser energy has lost much, so only the lower-order transversal modes and relatively stronger longitudinal modes reached threshold and produced their backward SBS light, the higher-order transversal modes (with a higher SBS intensity threshold) and weaker longitudinal modes did not produce their SBS light and have been eliminated in backward SBS beam. Therefore backward SBS has some mode-selecting ability, it can cleanup the broad-band Cr:LiSAF laser beam.

In conclusion, Our experimental results and illustrative analysis have demonstrated that frequency-dispersive method can efficiently reduce the intensity threshold of Q-switched Cr:LiSAF laser's broad-band SBS, compress pulsewidth (ratio is about 5 times), and improve beam quality.

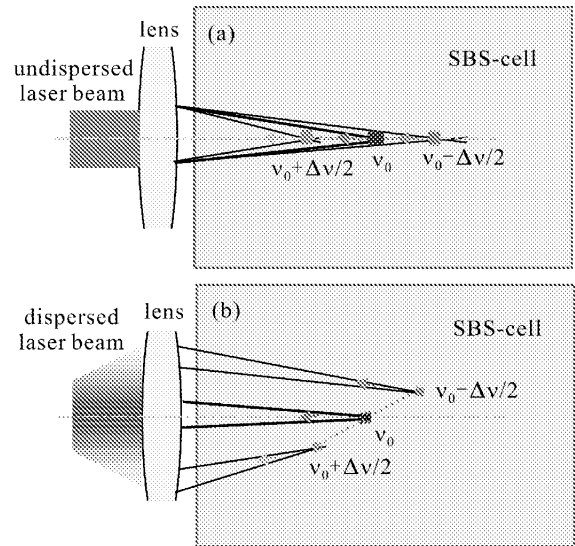

Fig. 6. Illustrative diagrams of focusing characteristic for undispersed laser beam (a) and dispersed laser beam (b).

This work was supported by the China National 863 Hi-technology Programs. We thank Changshui Chen, Dejie Tao and Yan Hang for their helps. C. Ge's e-mail address is gcwen@hotmail.com.

References

1. S. A. Payne, L. L. Chase, L. K. Smith, W. L. Kway, and H. W. Newkirk, *J. Appl. Phys.* **66**, 1051 (1989).
2. T. Shimada, J. W. Early, C. S. Lester, and N. J. Cockroft, in *Advanced Solid-State Lasers, Vol. 20 of OSA Proceedings Series* (Optical Society of America, Washington, D. C., 1994) pp. 188 – 191.
3. G. D. Boy and D. A. Kleinman, *J. Appl. Phys.* **39**, 3597 (1968).
4. A. A. Filippo and M. R. Perrone, *Appl. Phys. B* **57**, 103 (1993).
5. G. M. Davis and M. C. Gower, *IEEE J. Quantum Electron.* **27**, 496 (1991).
6. G. C. Valley, *IEEE J. Quantum Electron.* **22**, 704 (1986).
7. M. R. Perrone and Y. B. Yao, *Appl. Phys. Lett.* **64**, 19 (1994).
8. M. Stalder, B. H. T. Chai, and M. Bass, *Appl. Phys. Lett.* **58**, 216 (1991).
9. W. Koechner, *Solid-State Laser Engineering* (Springer-Verlag, New York/Heidelberg/Berlin, 1976) pp. 212 – 217.
10. J. M. Telle and R. G. Wenzel, *J. Opt. Soc. Am. B* **3**, 1489 (1986).